

# Gli acceleratori di particelle

*David Alesini*

*Divisione Acceleratori*

*INFN Frascati*



# WHAT CAN PARTICLE ACCELERATORS DO?

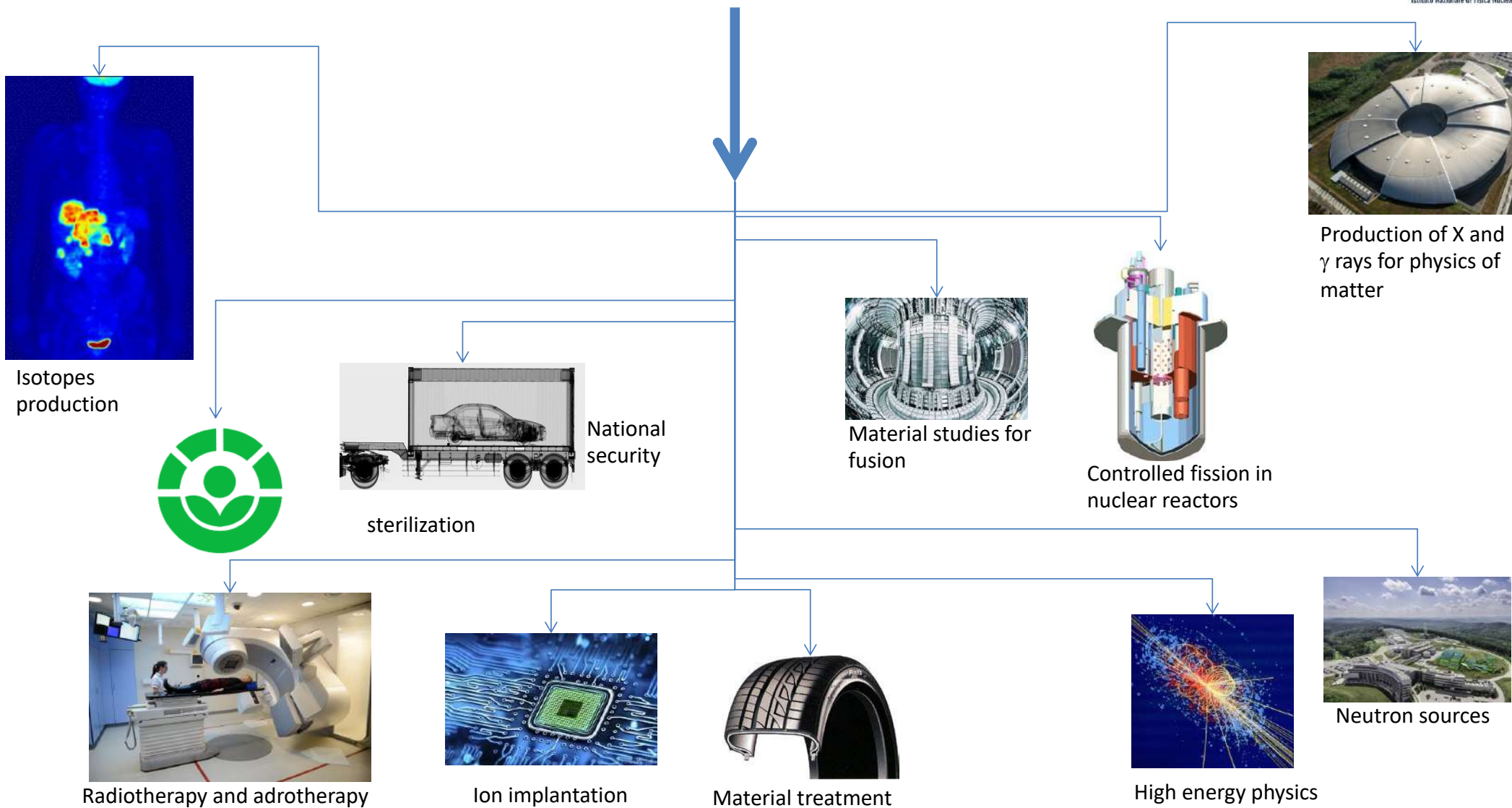

# World-wide Accelerators

~ 40,000...

from *Basic Science to Society!*

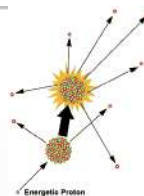

## Research

1%

- Particle colliders for High energy Physics (HEP) → LHC
- Betatrons, Cyclotrons
- Light Sources (Synchrotrons, FEL, Compton)
- Spallation sources

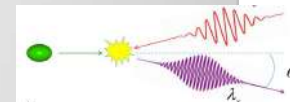

Cancer Radiation Therapy (RT)



## Medicine

44%

- Radio-isotopes for medical imaging/nuclear medicine

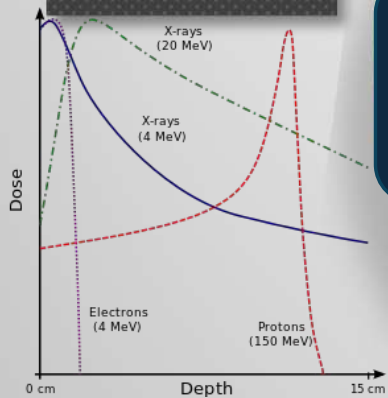

Security and Inspection



- Ion Implantation in Semiconductor Chip
- Fabrication/Processing of Polymers

Industry  
55%



- Electron Beam Sterilization of Medical Disposables
- Food Processing



Nondestructive testing (NDT)



Environment

# COME FUNZIONANO GLI ACCELERATORI DI PARTICELLE?

Un acceleratore di particelle può essere considerato come un **dispositivo che trasferisce energia a particelle cariche** (elettroni, protoni, ioni,...) attraverso campi elettro-magnetici.

SORGENTE

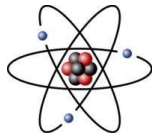

ACCELERATORE



UTILIZZATORE

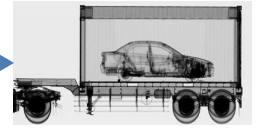

SORGENTE

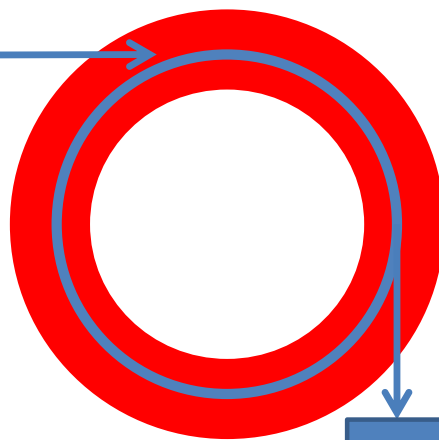

UTILIZZATORE

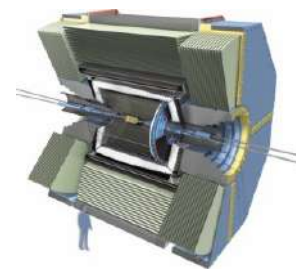

Fermilab Accelerator Complex



# INTERDISCIPLINARIETÀ DELLA FISICA E TECNOLOGIA DEGLI ACCELERATORI DI PARTICELLE

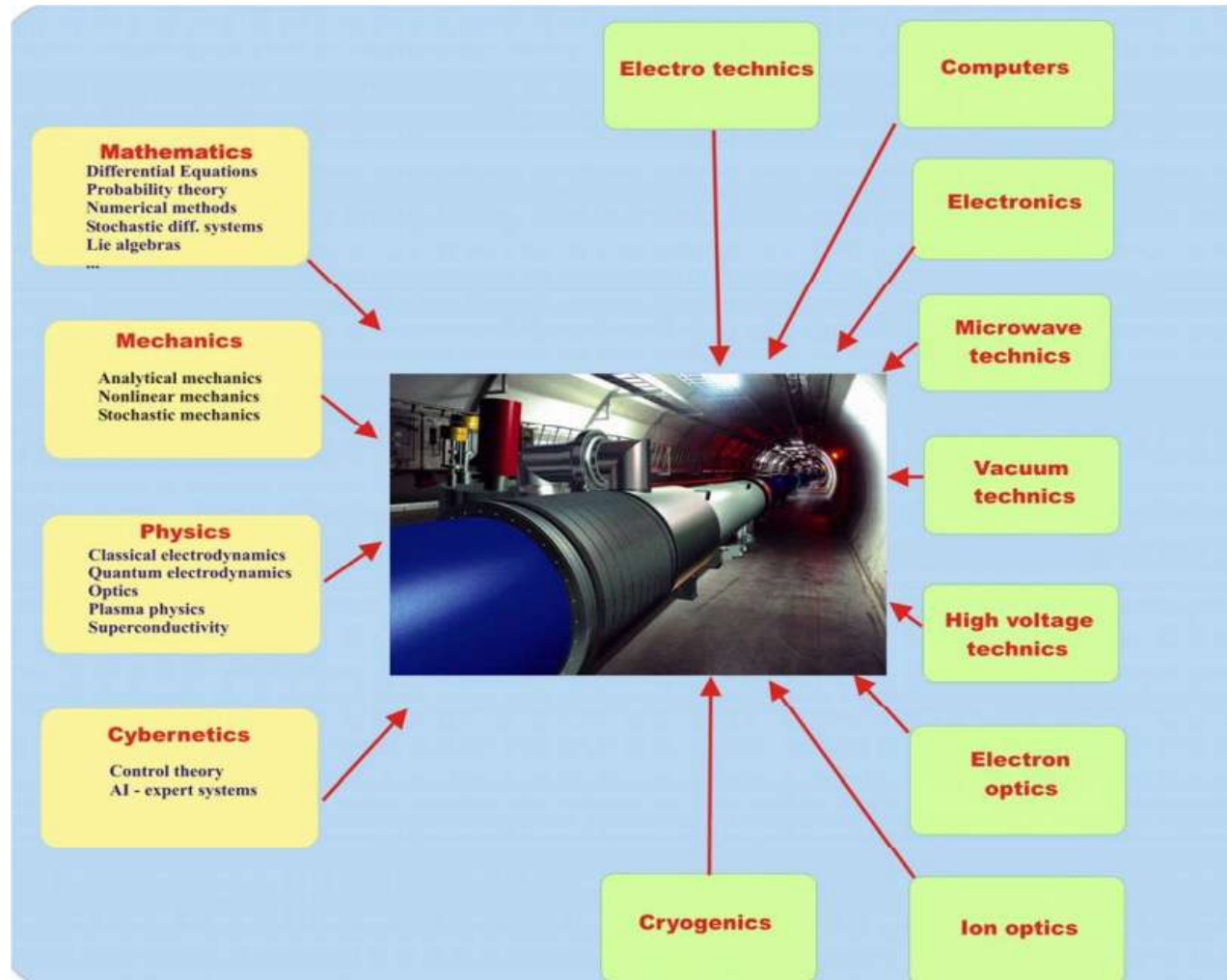

# SORGENTI DI PARTICELLE

## Elettroni

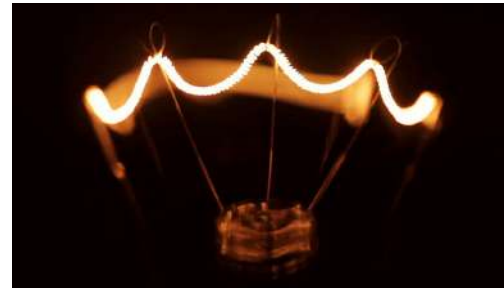
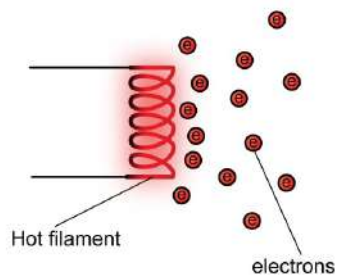
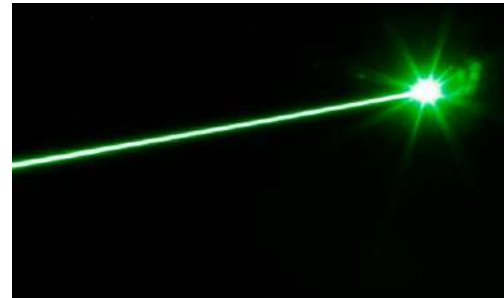
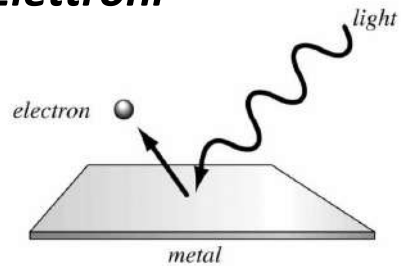

Gli **Elettroni** possono essere prodotti attraverso impulsi di luce laser che colpiscono una superficie metallica (effetto **foto-elettrico**) o filamenti portati all'incandescenza (**effetto termoionico**).

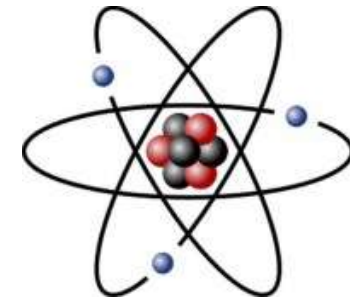

## Protoni

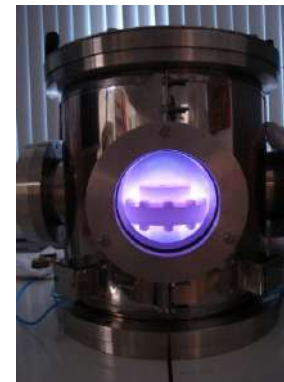
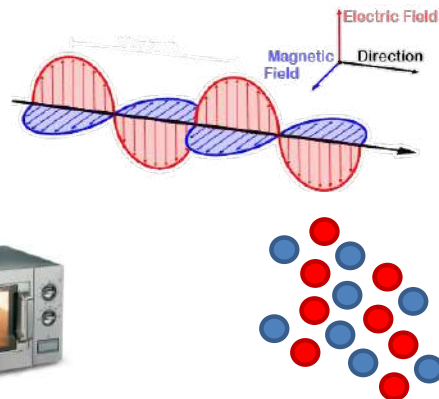
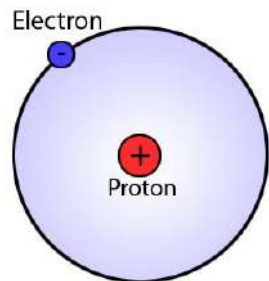

I **protoni** possono essere generati a partire da molecole di **idrogeno** che vengono portate allo stato di plasma da sorgenti a radiofrequenza

# BASIC EQUATION FOR PARTICLE ACCELERATORS

Beams of charged particles are accelerated with the use of **electric fields** and are deflected, curved, and focused with the use of **magnetic fields**. The basic equation for the description of the acceleration and focusing processes is represented by the **Lorentz Force**.

$$\frac{d\vec{p}}{dt} = q(\vec{E}_{acc} + \vec{v} \times \vec{B})$$

$\vec{p}$  = momentum  
 $m$  = mass  
 $\vec{v}$  = velocity  
 $q$  = charge

## ACCELERATION

To accelerate, we need a force in the direction of motion

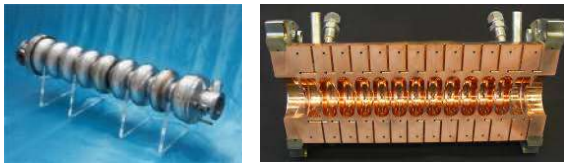
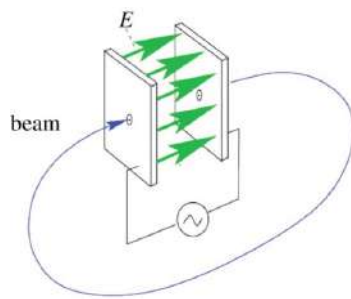

Longitudinal Dynamics

## BENDING AND FOCUSING

2<sup>nd</sup> term always perpendicular to motion => no energy gain

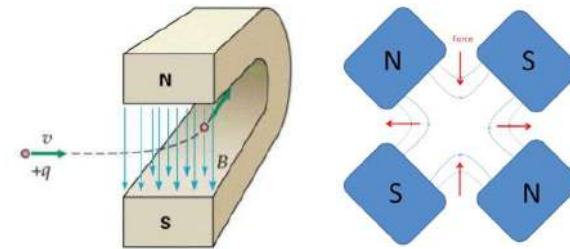

Transverse Dynamics

# ACCELERAZIONE DI PARTICELLE: CAMPO ELETTRICO

Le particelle vengono accelerate con l'utilizzo di **campi elettrici**

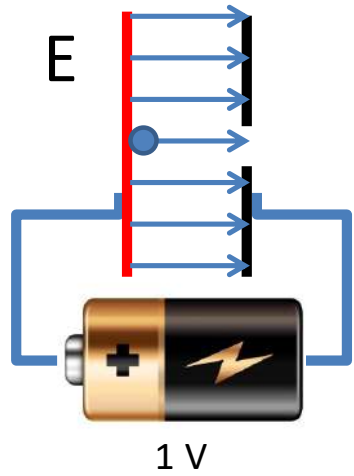

$10^9 - 10^{10}$  V

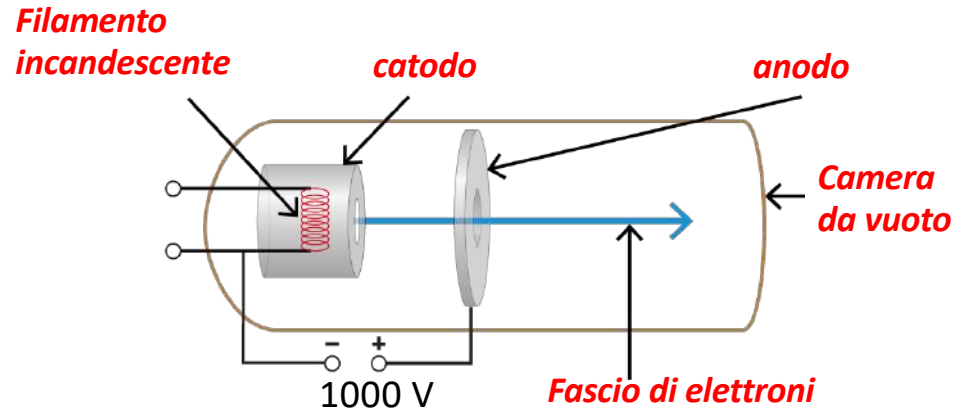

Guadagno di Energia  $\propto$  ddp (V)



220 V



$10^5$  V

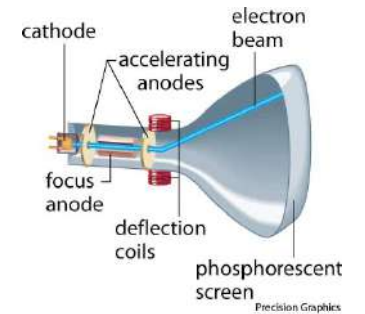

# ACCELERATION: SIMPLE CASE

The **first historical linear particle accelerator** was built by the Nobel prize Wilhelm Conrad Röntgen (1900). It consisted in a vacuum tube containing a cathode connected to the negative pole of a DC voltage generator. **Electrons emitted by the heated cathode** were accelerated while flowing to another electrode connected to the positive generator pole (anode). Collisions between the energetic electrons and the anode produced **X-rays**.

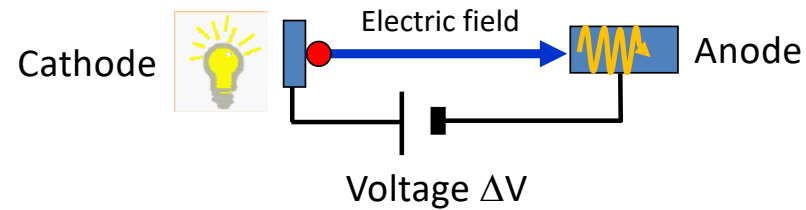

**Bertha  
Röntgen's Hand  
8 Nov, 1895**

The **energy gained** by the electrons travelling from the cathode to the anode is equal to their charge multiplied the DC voltage between the two electrodes.

$$\frac{d\vec{p}}{dt} = q\vec{E} \Rightarrow \Delta E = q\Delta V$$

$\vec{p}$  = momentum

$q$  = charge

$E$  = energy

Particle energies are typically expressed in **electron-volt [eV]**, equal to the energy gained by 1 electron accelerated through an electrostatic potential of 1 volt:  
1 eV =  $1.6 \times 10^{-19}$  J

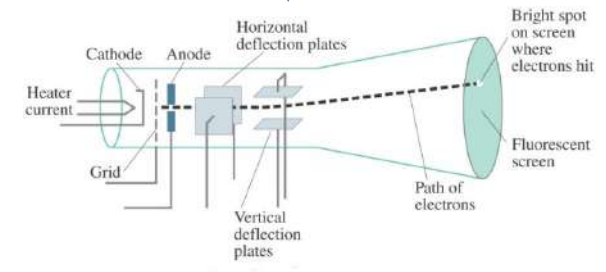

# PARTICLE VELOCITY VS ENERGY: LIGHT AND HEAVY PARTICLES

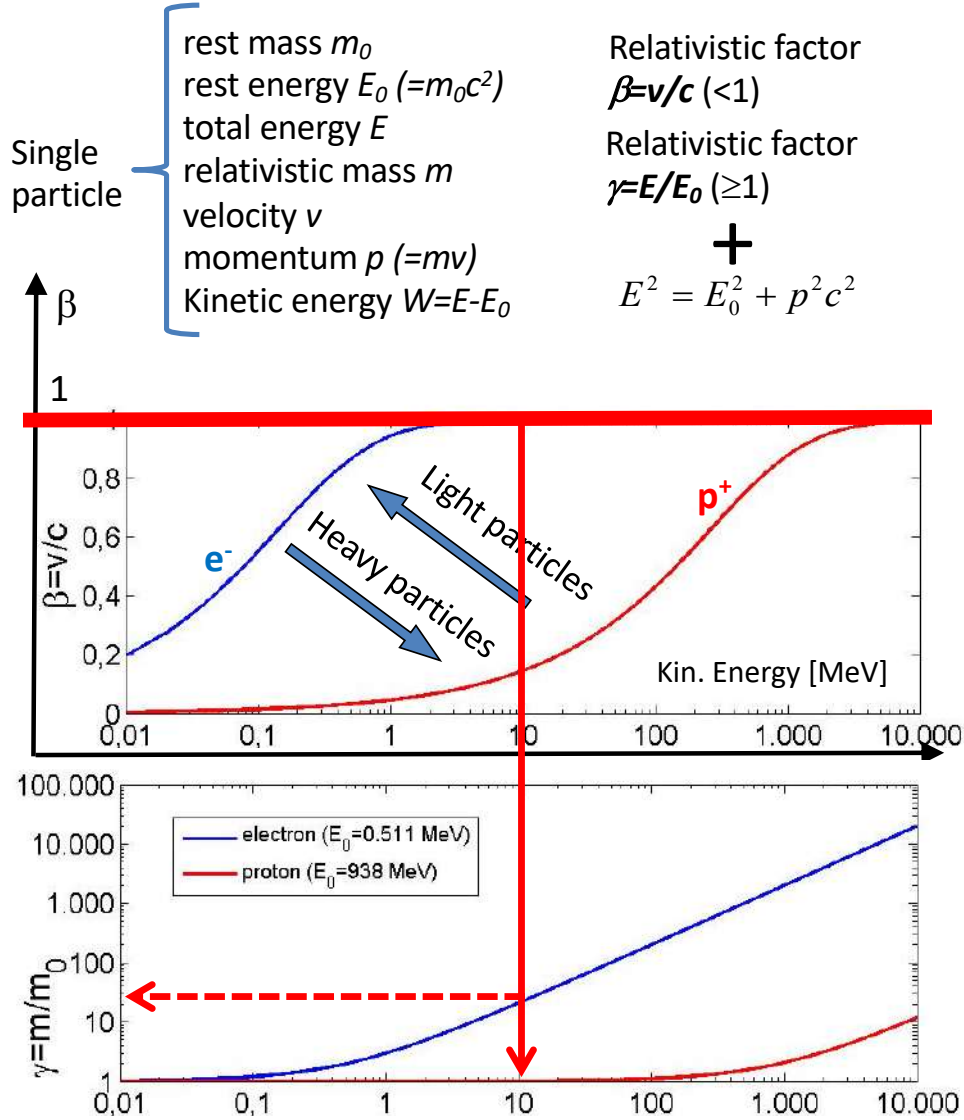

$$\begin{cases} \beta = \sqrt{1 - 1/\gamma^2} \\ \gamma = 1/\sqrt{1 - \beta^2} \quad (m = \gamma m_0) \\ W = E - E_0 = (\gamma - 1)m_0c^2 \approx \frac{1}{2}m_0v^2 \quad \text{if } \beta \ll 1 \end{cases}$$

$$\beta = \sqrt{1 - \frac{1}{\gamma^2}} = \sqrt{1 - \left(\frac{E_0}{E}\right)^2} = \sqrt{1 - \left(\frac{E_0}{E_0 + W}\right)^2}$$

⇒ **Light particles** (as **electrons**) are practically fully relativistic ( $\beta \approx 1$ ,  $\gamma \gg 1$ ) at relatively low energy and **reach a constant velocity** ( $\sim c$ ). The acceleration process occurs at constant particle velocity

⇒ **Heavy particles** (**protons and ions**) are typically weakly relativistic and **reach a constant velocity only at very high energy**. The velocity changes a lot during the acceleration process.



⇒ This implies **important differences** in the technical characteristics of the **accelerating structures**. In particular for **protons and ions** we need different types of accelerating structures, **optimized for different velocities** and/or the accelerating structure has to vary its geometry to take into account the velocity variation.

# ELECTROSTATIC ACCELERATORS

To increase the achievable maximum energy, Van de Graaff invented an electrostatic generator based on a **dielectric belt** transporting positive charges to an isolated electrode hosting an **ion source**. The positive ions generated in a large positive potential were accelerated toward ground by the static electric field.

## LIMITS OF ELECTROSTATIC ACCELERATORS

DC voltage as large as  $\sim 10$  MV can be obtained ( $E \sim 10$  MeV). The main limit in the achievable voltage is the **breakdown** due to **insulation** problems.

## APPLICATIONS OF DC ACCELERATORS

DC particle accelerators are in operation worldwide, typically at  $V < 15$  MV ( $E_{\max} = 15$  MeV),  $I < 100$  mA.

They are used for:

- ⇒ *material analysis*
- ⇒ *X-ray production,*
- ⇒ *ion implantation for semiconductors*
- ⇒ *first stage of acceleration (particle sources)*

750 kV Cockcroft-Walton  
Linac2 injector at CERN from 1978 to 1992

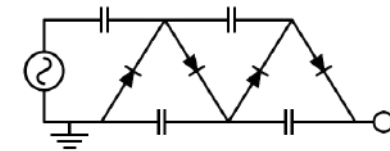
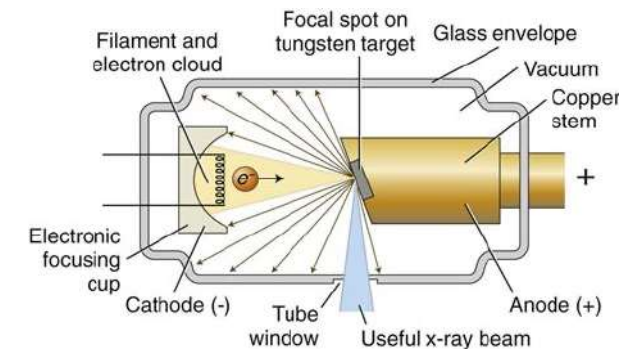
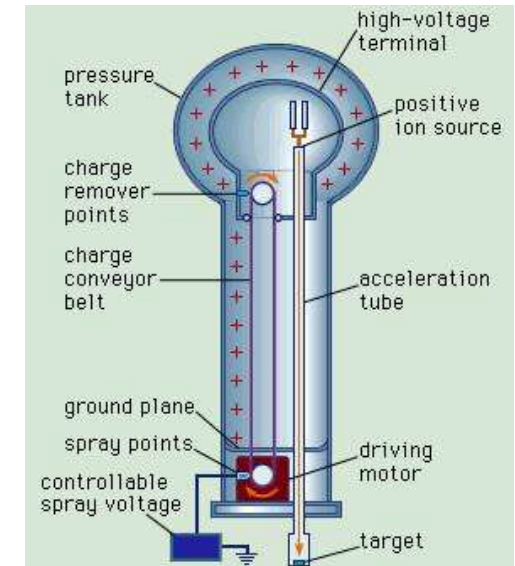

# RF ACCELERATORS: WIDERÖE “DRIFT TUBE LINAC” (DTL)

Basic idea: the particles are accelerated by the electric field in the gap between electrodes connected alternatively to the poles of an AC generator. This original idea of **Ising** (1924) was implemented by **Wideroe** (1927) who applied a sine-wave voltage to a sequence of **drift tubes**. The particles **do not experience any force while travelling inside the tubes** (equipotential regions) and are **accelerated across the gaps**. This kind of structure is called **Drift Tube LINAC (DTL)**.

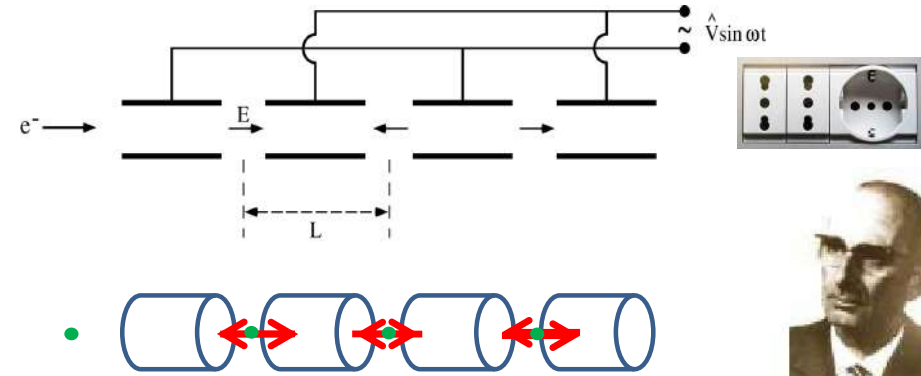

Rolf Wideroe

With modern particle accelerators, we can now accelerate particles with energy up to thousands of GeVs.  
Up to thousands of lightnings!

$10^9 - 10^{10}$  V

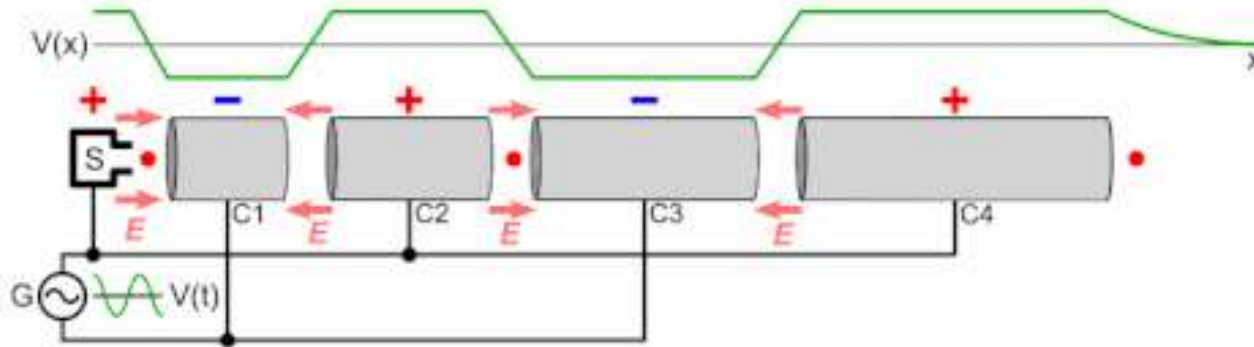

# ELECTROSTATIC ACCELERATION: CONTINUOUS BEAM

We consider the acceleration between two electrodes in DC.

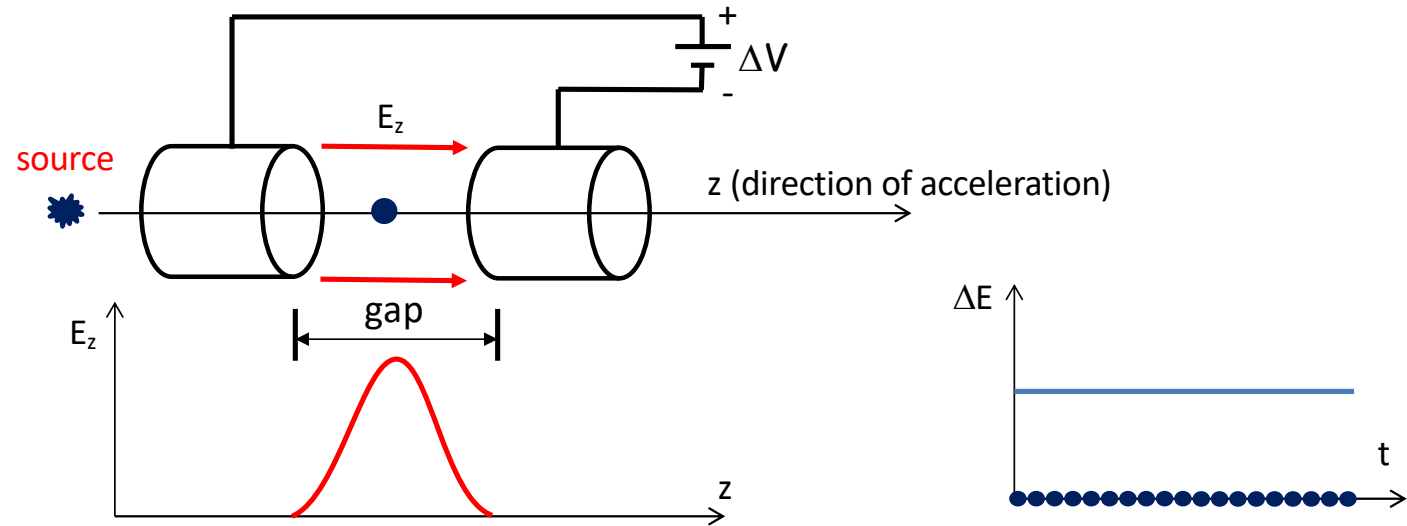

Energy-momentum relation

$$E^2 = E_0^2 + p^2 c^2 \Rightarrow 2E dE = 2p dp c^2 \Rightarrow dE = v \frac{mc^2}{E} dp \Rightarrow dE = v dp$$

Lorentz force  $\frac{dp}{dt} = qE_z \xrightarrow{z=vt} v \frac{dp}{dz} = qE_z \Rightarrow \boxed{\frac{dE}{dz} = qE_z}$  (and also  $\frac{dW}{dz} = qE_z$ )  $W = E - E_0$

rate of energy gain per unit length

$$\Rightarrow \Delta E = \int_{gap} \frac{dE}{dz} dz = \int_{gap} qE_z dz \Rightarrow \boxed{\Delta E = q\Delta V}$$

energy gain per electrode pair

# RF ACCELERATION: BUNCHED BEAM

We consider now the acceleration between two electrodes fed by an RF generator

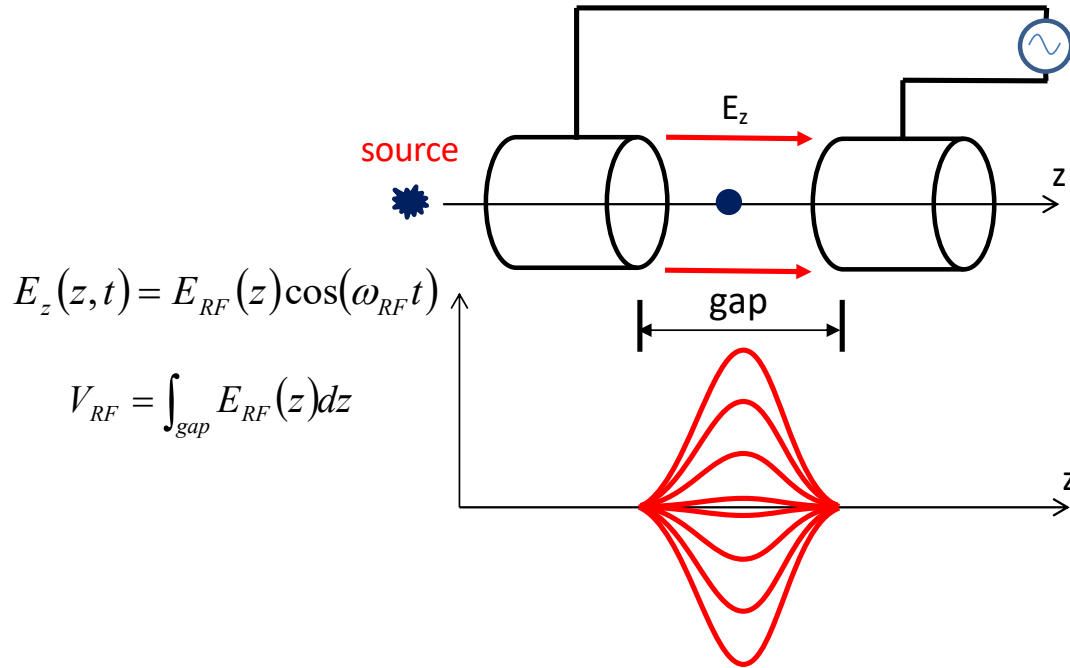

$$\Delta V = V_{RF} \cos(\omega_{RF} t) \quad \omega_{RF} = 2\pi f_{RF} = \frac{2\pi}{T_{RF}}$$

$$\Rightarrow \Delta E = q \hat{V}_{acc} \cos(\omega_{RF} t_{inj})$$

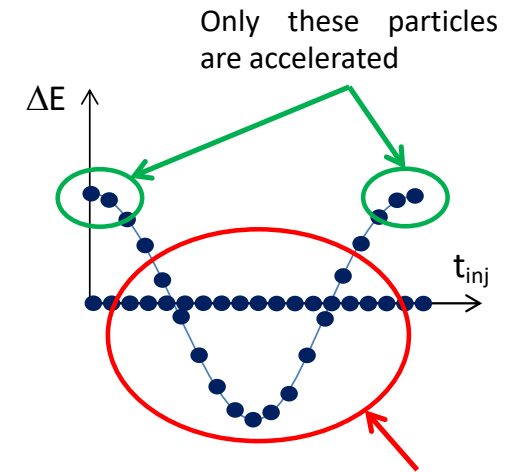

These particles are not accelerated and basically are lost during the acceleration process

**DC acceleration**

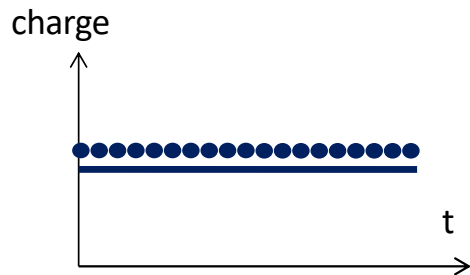

**RF acceleration**

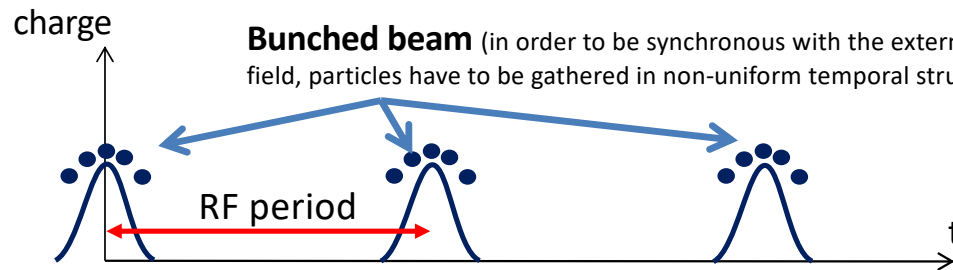

# CAVITÀ A RADIOFREQUENZA

Nei LINACs le **cavità risonanti** sono quasi sempre raggruppate in **strutture multicella**. Questa scelta è motivata da ragioni di **economicità e compattezza**. In una struttura multicella un unico accoppiatore RF è sufficiente ad eccitare il campo. Questo implica l'uso di un numero ridotto di sorgenti di alta potenza RF, a beneficio della semplicità e dei costi dell'acceleratore. L'accoppiamento tra le celle si realizza attraverso **iridi** in ciascuna cella e/o attraverso aperture realizzate appositamente tra le celle (slots di accoppiamento).

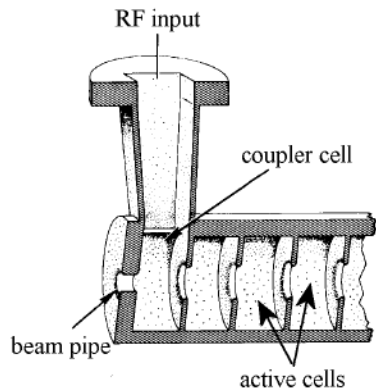
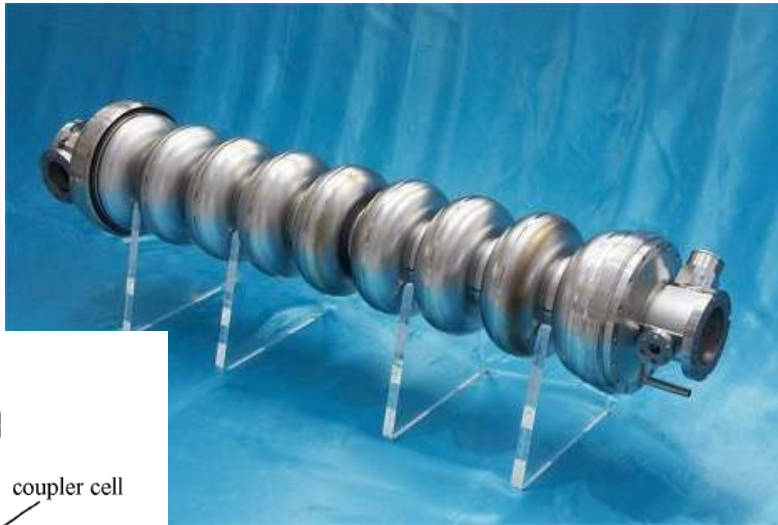

Esistono sia cavità che operano a **temperatura ambiente** (tipicamente in rame) che **cavità superconduttive** che operano a qualche K. I **gradienti acceleranti medi** che si possono tipicamente ottenere sono dell'ordine di **qualche 10 MV/m**. Tali gradienti possono arrivare anche a **>100 MV/m**.

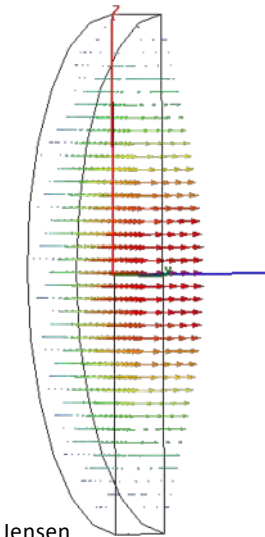

Courtesy E. Jensen

Le **frequenze di lavoro** possono andare dal MHz alla decina di GHz a seconda delle applicazioni

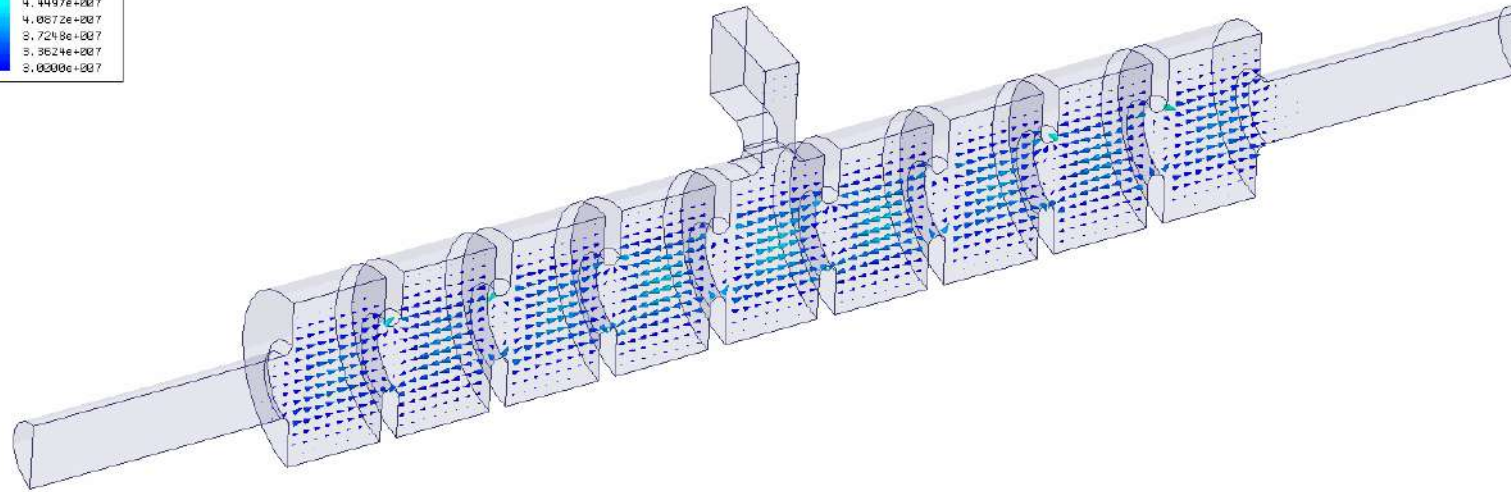
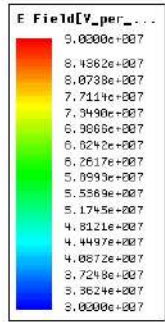

# ALVAREZ STRUCTURES: EXAMPLES



CERN LINAC 2 tank 1:  
200 MHz 7 m x 3 tanks, 1 m  
diameter, final energy 50 MeV.

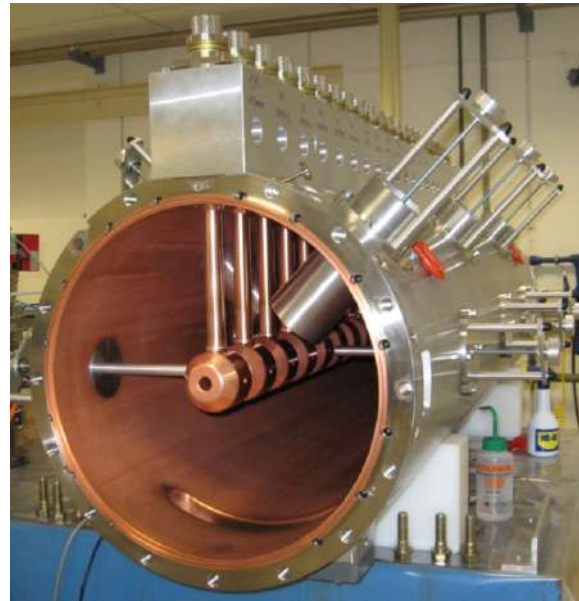

CERN LINAC 4: 352 MHz frequency, Tank diameter 500 mm, 3 resonators (tanks), Length 19 m, 120 Drift Tubes, Energy: 3 MeV to 50 MeV,  $\beta=0.08$  to 0.31  $\rightarrow$  cell length from 68mm to 264mm.

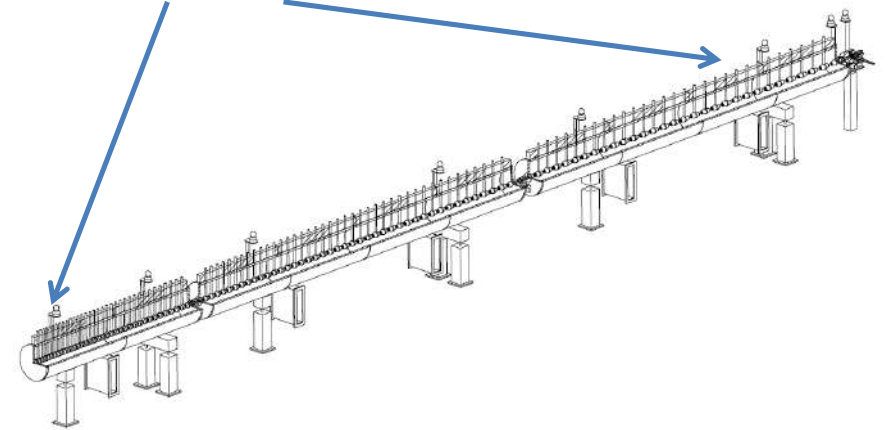

# SW AND TW ACCELERATING CAVITIES

$$\frac{d\vec{p}}{dt} = q(\vec{E} + \vec{v} \times \vec{B})$$

To accelerate charged particles, the RF wave must have an **electric field along the direction of propagation of the particle**. There are basically two possibilities:

1-Using **standing wave (SW)** TM<sub>010</sub>-like modes in a **resonant cavity** (or multiple resonant cavities) in which the beam is synchronous with the resonating field;

2-Using a **travelling wave (TW) disk loaded** structure operating on the TM<sub>01</sub>-like mode in which the RF wave is co-propagating with the beam with a phase velocity equal to the beam velocity (c for e<sup>-</sup>).

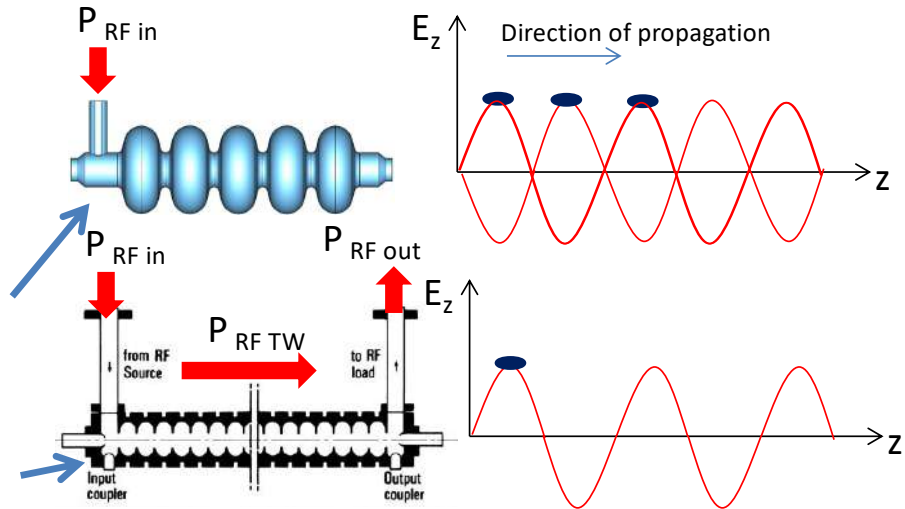

⇒The structures are powered by RF generators (typically **klystrons**).

⇒The cavities (and the related LINAC technology) can be of different material:

- copper for **normal conducting (NC, typically TW)** cavities;
- Niobium for **superconducting cavities (SC, typically SW)**;



# LORENTZ FORCE: ACCELERATION AND FOCUSING

Particles are accelerated through electric field and are bended and focalized through magnetic field.  
The basic equation that describe the acceleration/bending /focusing processes is the **Lorentz Force**.

$$\frac{d\vec{p}}{dt} = q(\vec{E}_{acc} + \vec{v} \times \vec{B})$$

$\vec{p}$  = momentum  
 $m$  = mass  
 $\vec{v}$  = velocity  
 $q$  = charge

## ACCELERATION

To accelerate, we need a force in the direction of motion

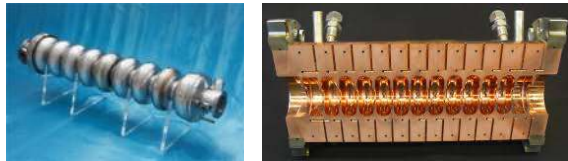
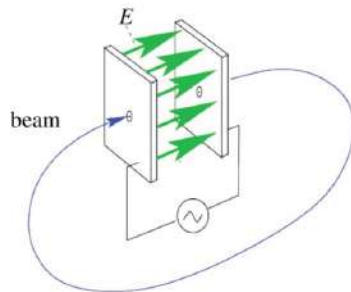

Longitudinal Dynamics

## BENDING AND FOCUSING

2<sup>nd</sup> term always perpendicular to motion => no energy gain

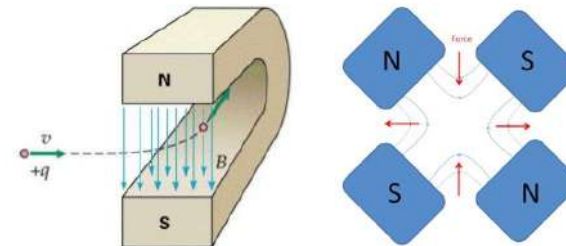

Transverse Dynamics

# COME SI CURVANO LE PARTICELLE: CAMPI MAGNETICI

Per curvare le particelle si utilizzano campi magneti generati da magneti permanenti o elettromagneti

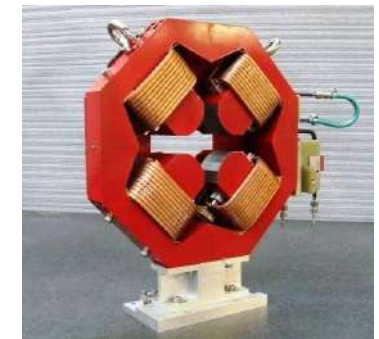
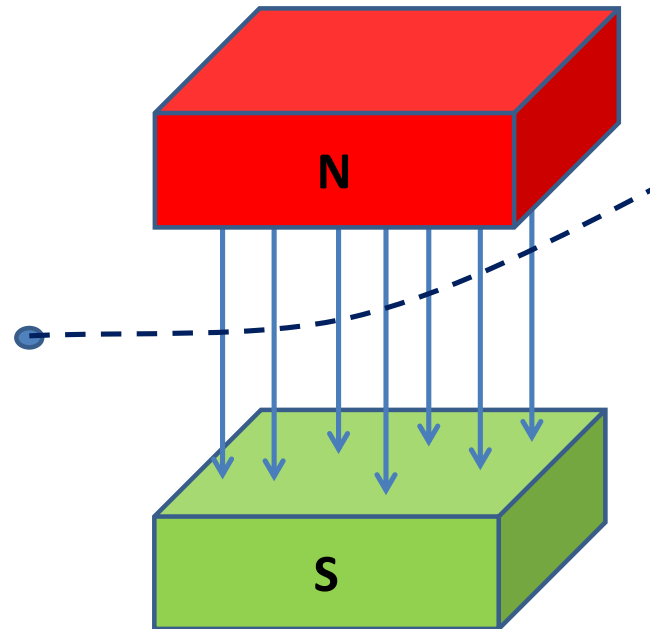
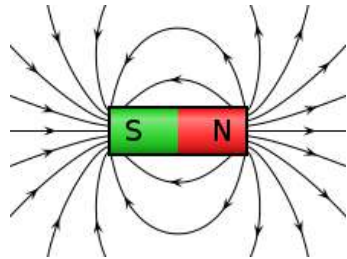

QUADRUPOLO

Quando una **particella carica** entra in un campo magnetico è soggetta ad una forza ortogonale alla velocità della particella e proporzionale al campo magnetico esercitato.

**Magneti dipolari** sono utilizzati per curvare le particelle

**Magneti quadrupolari** per focalizzarle

# DIPOLI: DEFLESSIONE

Consentono di curvare la traiettoria delle particelle. Possono essere realizzati con **magneti permanenti** o **elettromagneti** (poli ferro con avvolgimenti percorsi da corrente).

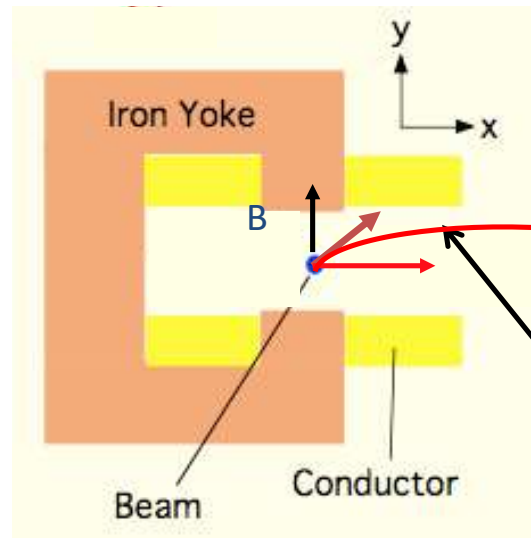
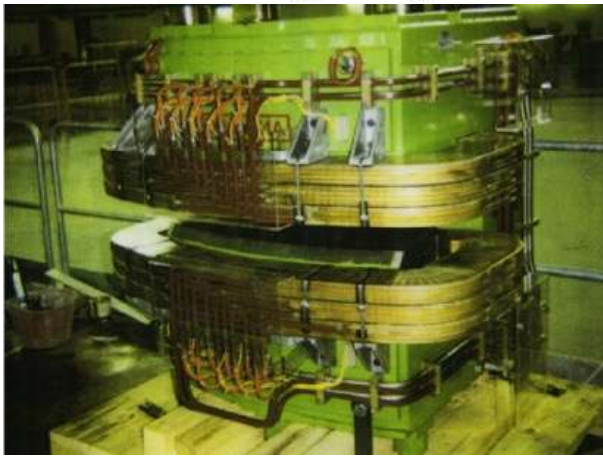
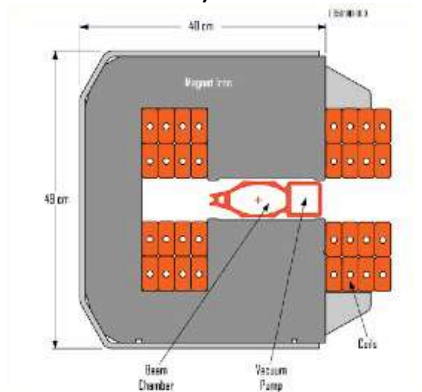

Traiettoria circolare

Raggio di curvatura

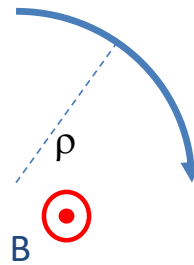

$$\rho = \frac{p}{qB}$$

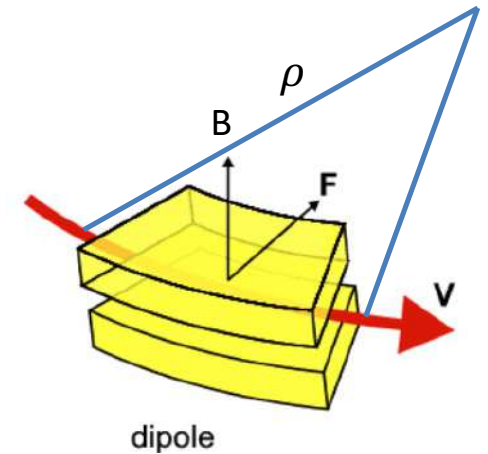

I dipoli elettromagnetici vengono usati per produrre  $B$  non oltre 1-2 T.  
Per campi magnetici più intensi si ricorre a **magneti superconduttori**

# MATERIALI SUPERCONDUTTORI

I **materiali superconduttori** al di sotto di una certa temperatura (dell'ordine di qualche Kelvin) offrono una **resistenza trascurabile** al passaggio della corrente.

Possono essere usati per costruire cavità o magneti con generare B fino a 10-15 T

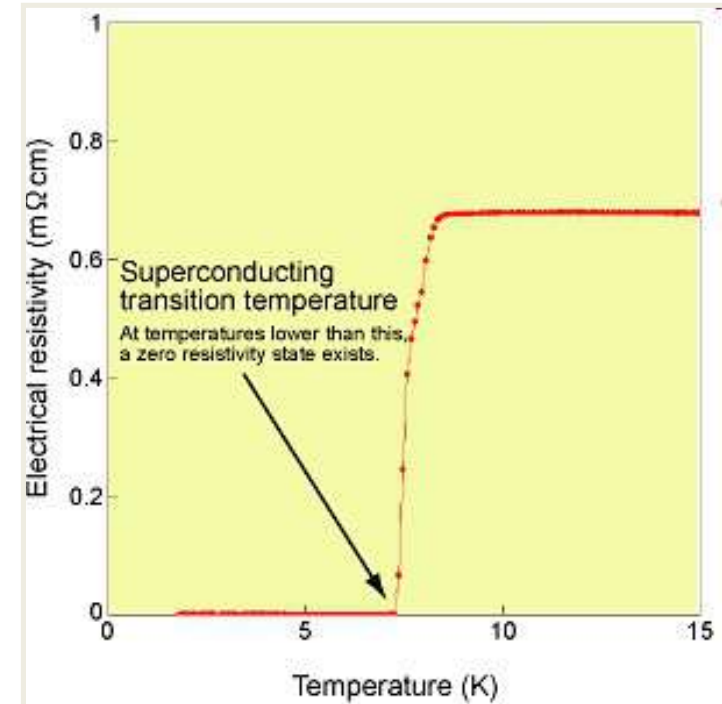

Basse temperature: 2 Kelvin = -271° C

Tali temperature sono ottenute raffreddando i conduttori con un dispositivo frigorifero che usa **He superfluido: il criostato**

# CICLOTRONI (1/2)

Nei ciclotroni l'accelerazione è realizzata tramite un *campo elettrico alternato* tra due o più elettrodi immersi in un *campo magnetico dipolare costante* (E.O.Lawrence-1930)

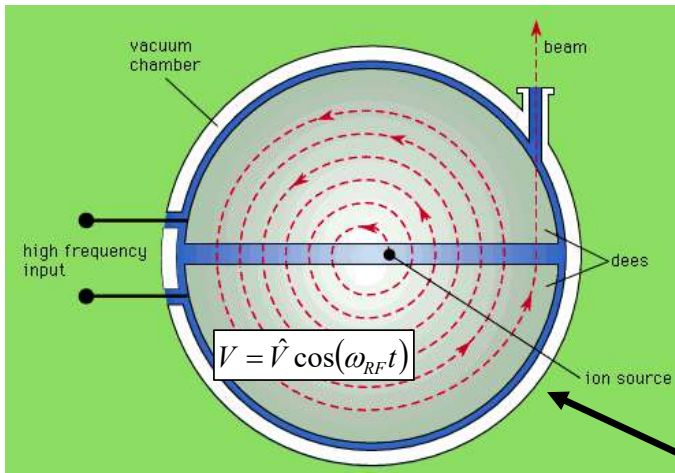

Traiettoria a spirale  $\rho = \frac{mv}{qB}$

Ad ogni *passaggio nel gap* tra i due elettrodi le particelle *guadagnano energia*.

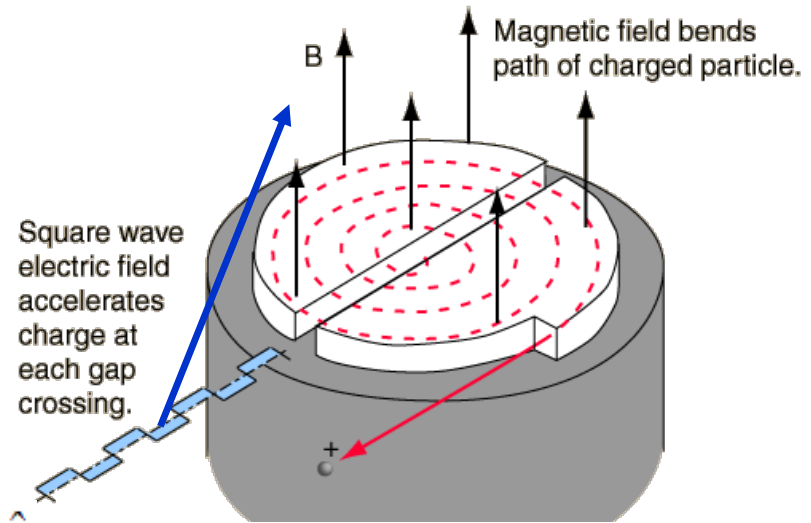

$$\Delta E = q\hat{V}$$

Il *sincronismo tra campo accelerante e particelle* si mantiene se è soddisfatta la relazione:

$$f_{RF} = hf_{rev} = h \frac{qB}{2\pi m}$$

I ciclotroni standard hanno una  $f_{RF}$  *costante* e, quindi, tale sincronismo è mantenuto perfettamente solo nel caso di *particelle non relativiche* ( $m=m_0=costante$ )

## CICLOTRONI (2/2)



Il *ciclotrone* è stato progettato con l'intenzione di superare le limitazioni dell'acceleratore lineare. All'epoca (1930) non era possibile generare onde radio contemporaneamente ad alta frequenza ed alta potenza, per cui gli stadi di accelerazione lineare (DTL) dovevano essere spazati tra loro ed erano necessari più stadi (per compensare la limitata potenza). **Per ottenere energie elevate era necessario costruire acceleratori lunghi** e, oltre un certo limite, troppo costosi.

Poiché il ciclotrone accelera le particelle su un percorso circolare, è possibile ottenere lunghi percorsi in poco spazio e può essere alimentato con un **unico e relativamente economico sistema elettronico**.

Nonostante i significativi miglioramenti raggiunti nel tempo, la struttura del dispositivo ne limita la convenienza economica per potenze molto elevate. Il problema principale è che per ottenere energie elevate è necessario **incrementare il diametro della camera a vuoto e del magnete** e dell'intensità del campo prodotto da questo. Trova comunque moltissime applicazioni nella prima **accelerazione di ioni**.

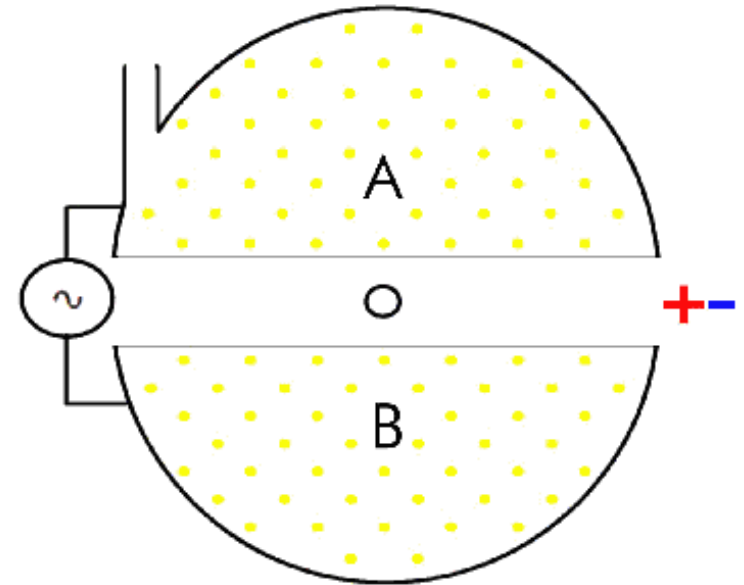

<https://youtu.be/cutKuFxeXmQ>

# QUADRUPOLO: FOCHEGGIAMENTO

E' un magnete con **4 poli** che focheggia le traiettorie delle singole particelle così come fa una lente con la luce.

Caratteristiche di B

- B=0 al centro
- L'intensità di **B cresce linearmente** ed in maniera proporzionale allo spostamento rispetto all'asse di riferimento

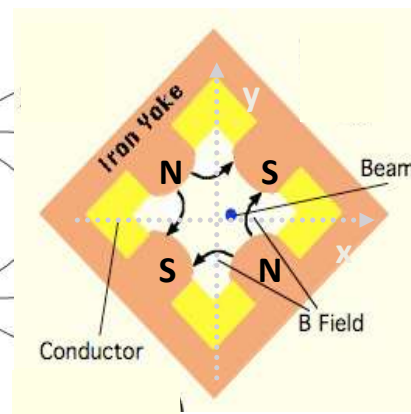
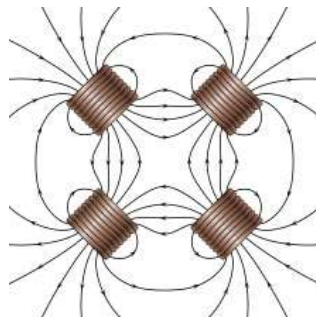
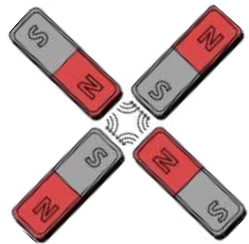

$$B_x = g \cdot y$$

$$B_y = g \cdot x$$

$$g = \left[ \frac{T}{m} \right]$$

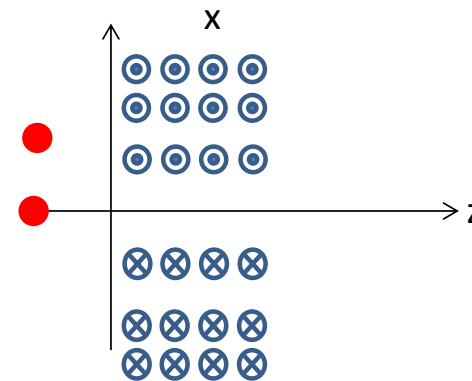

# FOCHEGGIAMENTO TRASVERSO: FUNZIONE $\beta$

Un *quadrupolo* foceggia il fascio in un piano e lo defoceggia nell'altro.

Per ottenere il *foccheggiamento complessivo* di un fascio di particelle lungo un canale di trasporto o in un acceleratore circolare bisogna usare una *sequenza di quadrupoli con il segno alternato*

Tale configurazione è in grado di garantire traiettorie stabili.

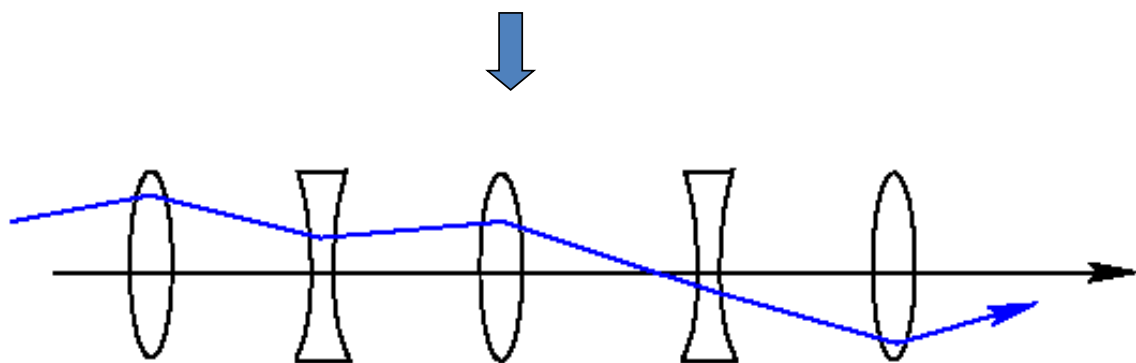

La *traiettoria trasversa descritta da ogni particella* è una pseudo-sinusoide.

L'inviluppo all'interno del quale sono confinate tutte le particelle del pacchetto è detto **funzione  $\beta$** .

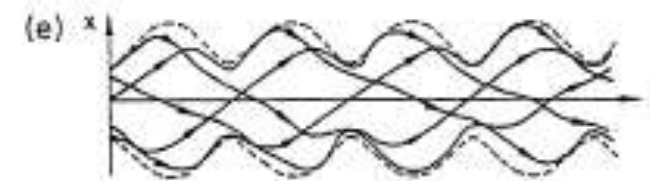
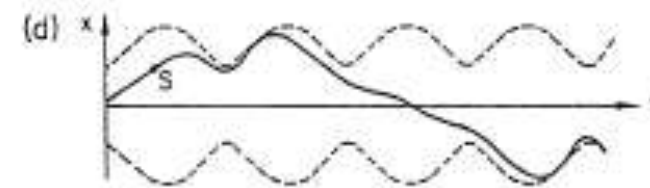
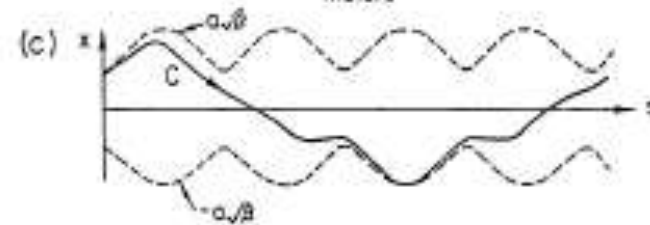
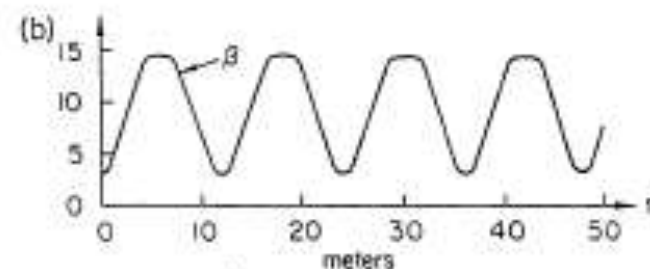

# ACCELERATORI LINEARI E SINCROTRONI

Un acceleratore lineare (**LINAC**) si presenta tipicamente come una **sequenza alternata di sezioni acceleranti, quadrupoli, elementi di diagnostica** che consentono di misurare la posizione delle particelle all'interno della camera da vuoto.



m → km

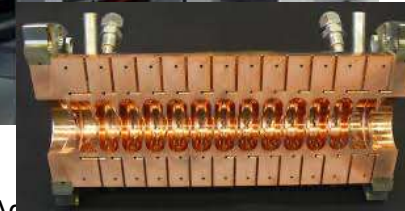
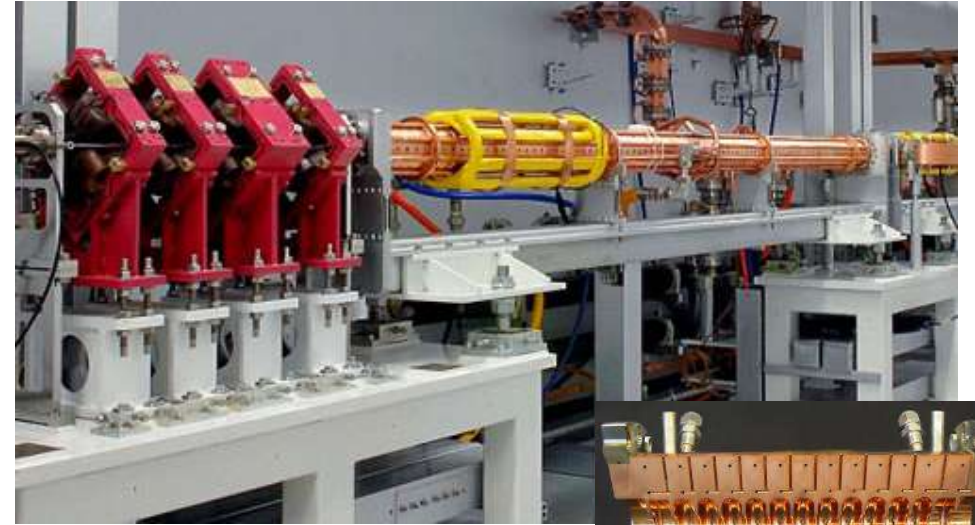

Con l'utilizzo di **dipoli** il fascio può anche essere fatto circolare all'interno di un anello in cui si ha un'unica cavità acceleratrice. Ad ogni passaggio il fascio di particelle acquista energia. Queste macchine sono dette **sincrotroni**.

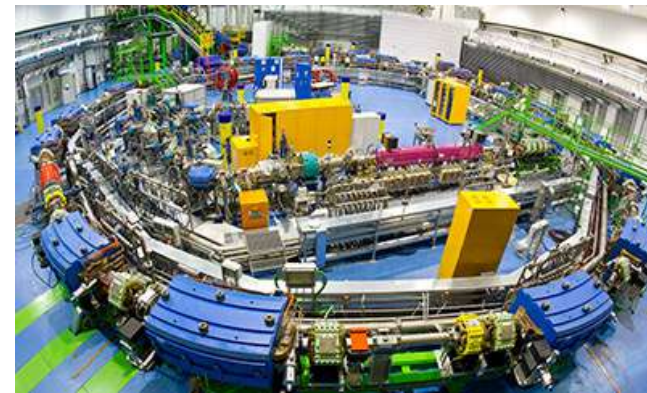
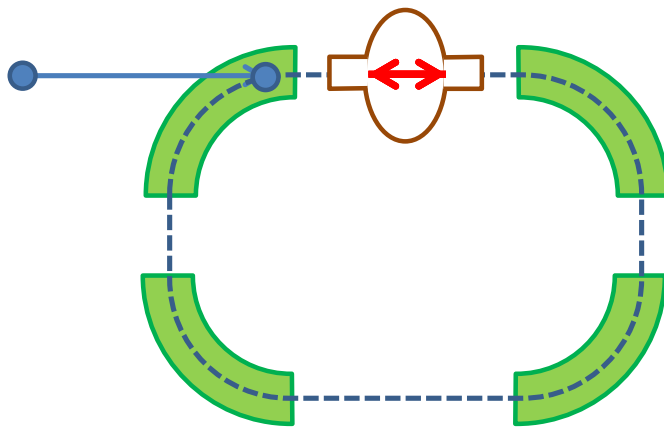

# ACCELERATORI CIRCOLARI: IL SINCROTRONE

Il *sincrotrone* è un acceleratore di particelle circolare.

A differenza del LINAC, nel sincrotrone, *le particelle descrivono orbite chiuse* grazie all'utilizzo di magneti curvati (*dipoli*) che deflettono le particelle. Il *campo elettrico è sincronizzato con il fascio* delle particelle in modo che ad ogni passaggio successivo in cavità queste aumentano la loro energia.

*B aumenta in modo da tenere il raggio dell'orbita costante* (Il valore di **B** non è illimitato quindi per raggiungere alte energie è necessario costruire acceleratori con un raggio molto grande).

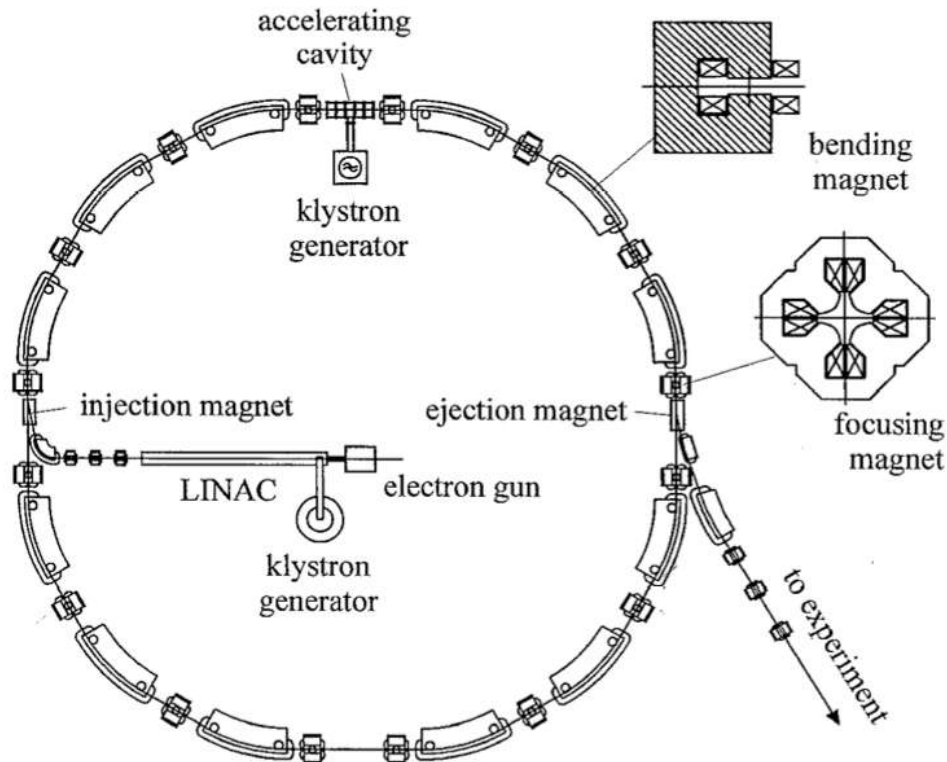

- DIPOLI** – determinano la traiettoria di riferimento
- QUADRUPOLI** – mantengono le oscillazioni di tutte le particelle intorno alla traiettoria di riferimento
- SESTUPOLI** – correggono l'effetto cromatico dei quadrupoli
- CAVITA' RF**- accelera il fascio
- CAMERA DA VUOTO**
- DIAGNOSTICA**



# ACCELERAZIONE IN UN SINCROTRONE

Il **campo elettrico** in cavità accelera le particelle e **non può essere elettrostatico** ma deve avere necessariamente **carattere oscillatorio** nel tempo altrimenti in un giro completo una particella guadagnerebbe energia nella cavità e la perderebbe nella rimanente parte dell'acceleratore-principio di (conservatività del campo elettrostatico).

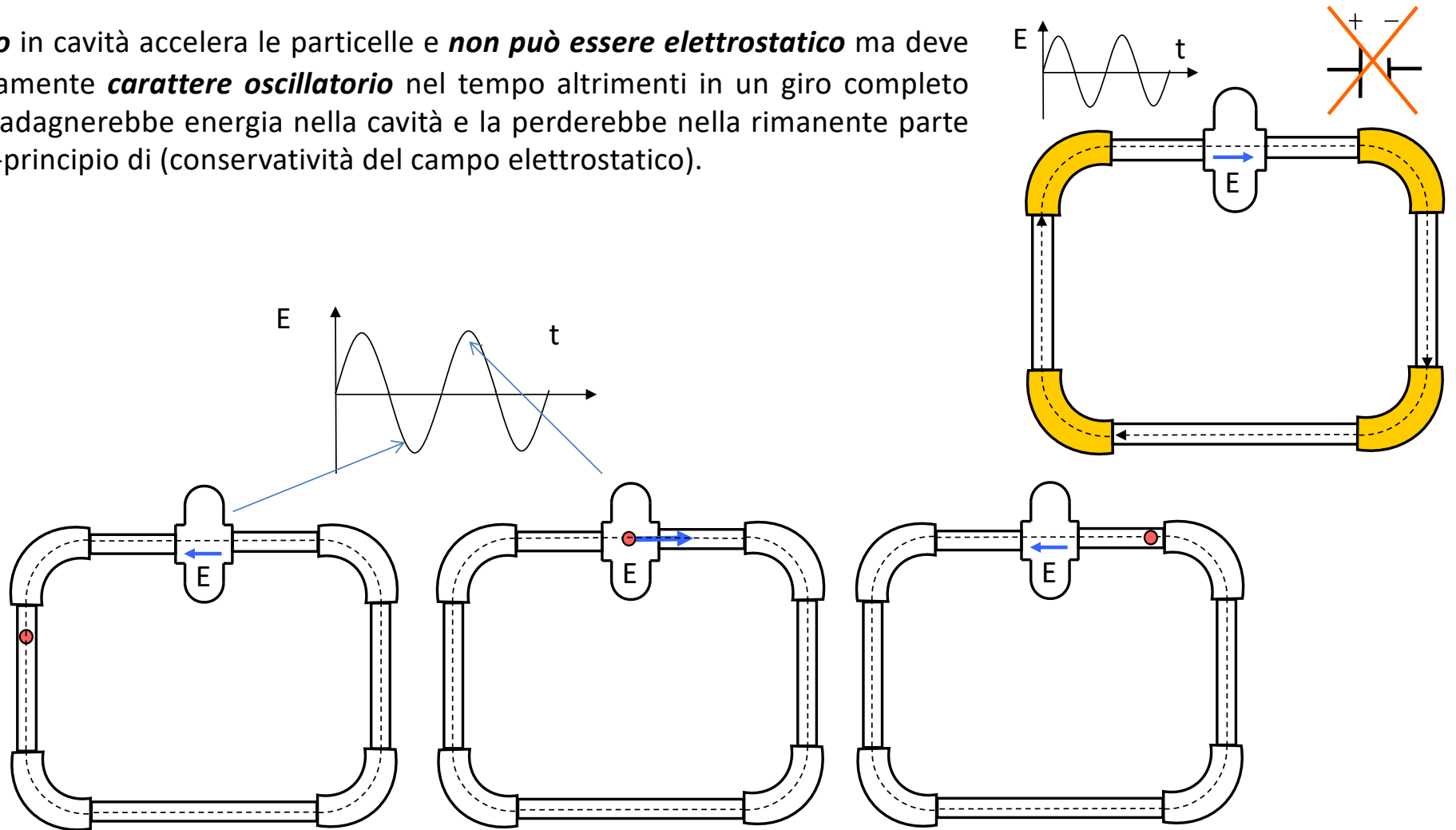

# PERIODO DI RIVOLUZIONE E NUMERO ARMONICO

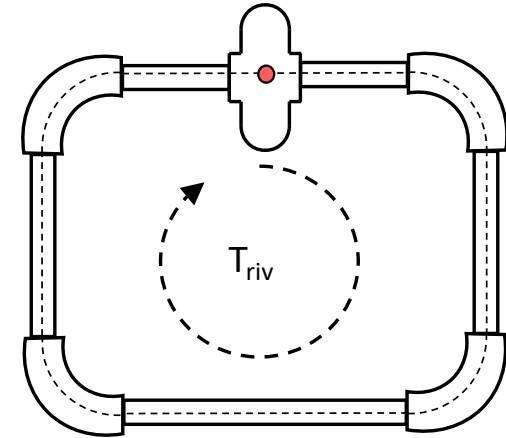
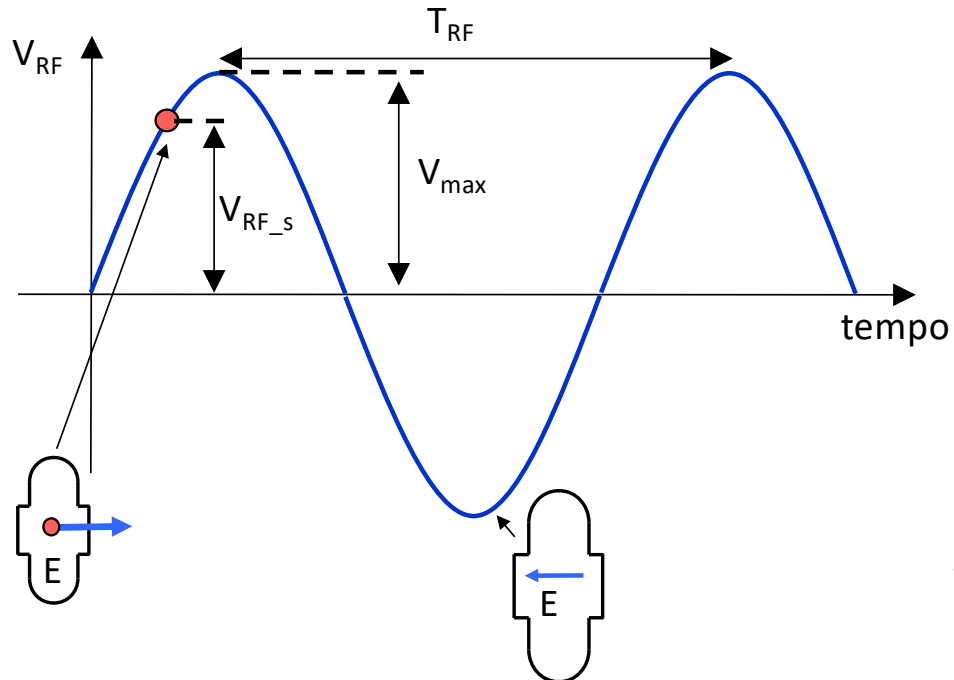

Il tempo impiegato dalla particella a descrivere un giro completo è detto **periodo di rivoluzione** ( $T_{riv}$ )

Per avere accelerazione “stabile” ovvero per fare in modo che la particella dopo un giro veda sempre la stessa tensione accelerante in cavità, il periodo di rivoluzione ( $T_{riv}$ ) deve essere un multiplo intero ( $h$ ) del periodo di radiofrequenza ( $T_{RF}$ ) ad ogni giro.

$h$  è detto **numero armonico** ed è pari al numero di “pacchetti” di particelle che può essere accelerato stabilmente nel sincrotrone.

$$T_{riv} = hT_{RF}$$

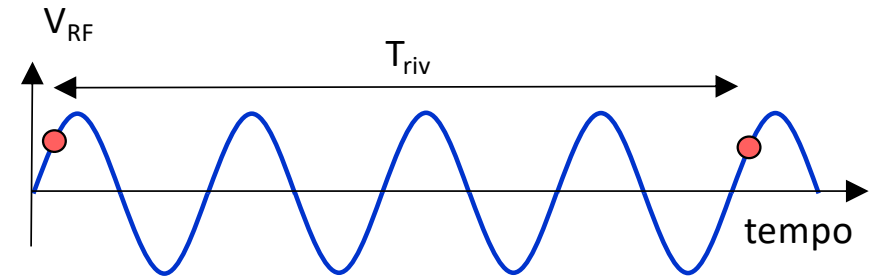

# ACCELERAZIONE-ENERGIA-VELOCITÀ

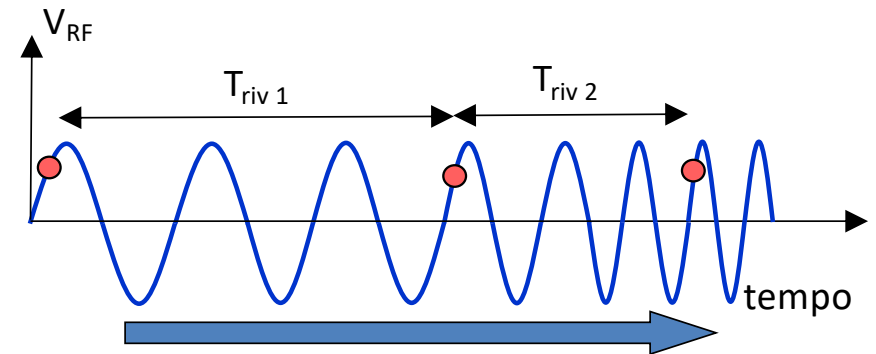
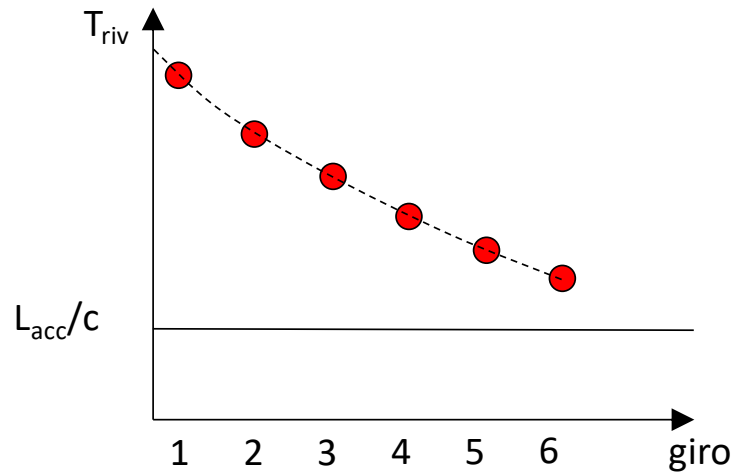
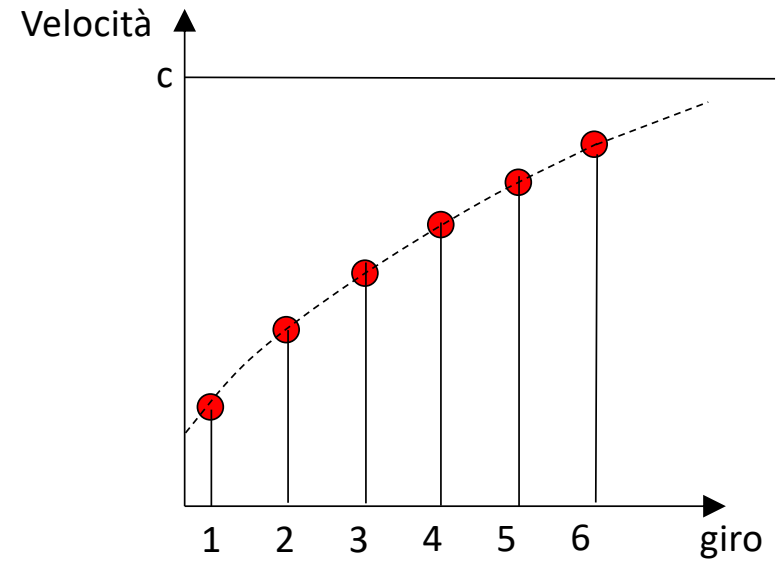
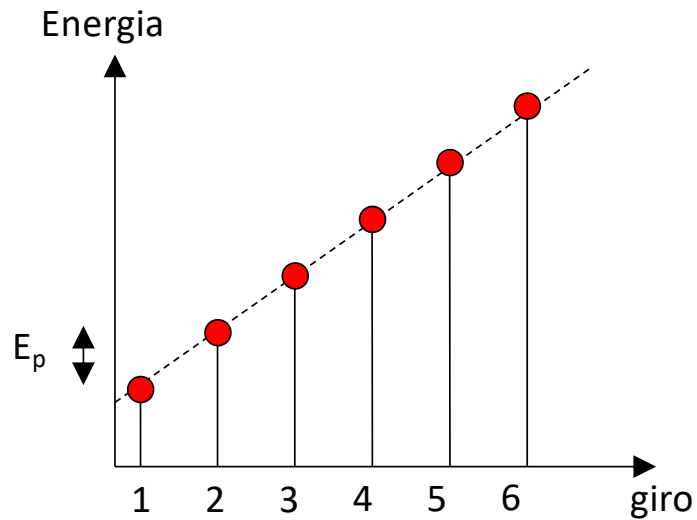

Durante l'accelerazione la **frequenza RF aumenta** per mantenere il sincronismo tra particella e campo accelerante: **sistema RF complesso**

# LORENTZ FORCE: ACCELERATION AND FOCUSING

Particles are accelerated through electric field and are bended and focalized through magnetic field.  
The basic equation that describe the acceleration/bending /focusing processes is the **Lorentz Force**.

$\vec{p}$  = momentum  
 $m$  = mass  
 $\vec{v}$  = velocity  
 $q$  = charge

$$\frac{d\vec{p}}{dt} = q(\vec{E}_{acc} + \vec{v} \times \vec{B})$$

## ACCELERATION

To accelerate, we need a force in the direction of motion

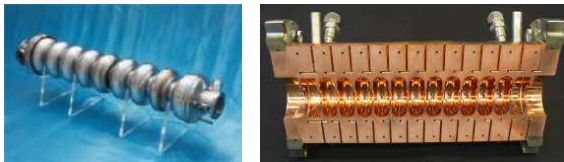
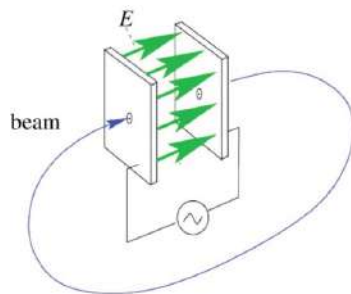

Longitudinal Dynamics

## BENDING AND FOCUSING

2<sup>nd</sup> term always perpendicular to motion => no energy gain

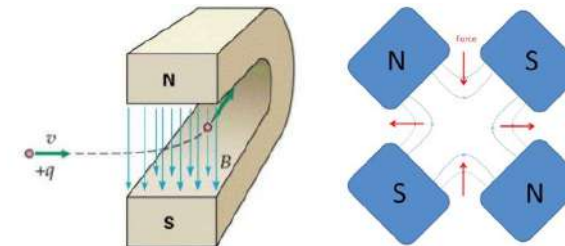

Transverse Dynamics

# CAMPO MAGNETICO

All'aumento di energia giro per giro deve corrispondere un **aumento dell'intensità del campo magnetico** dei dipoli (B) in modo tale da mantenere le particelle sempre sulla stessa orbita.

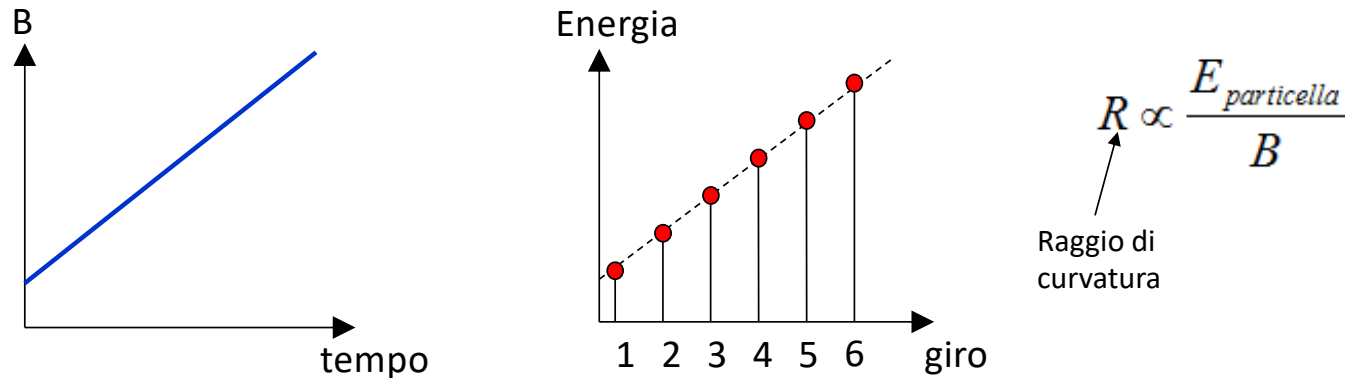

# PARTICELLA SINCRONA

La **particella sincrona** è quella particella che ad ogni giro:

- 1) ha l'energia nominale che le consente di descrivere sempre la stessa orbita di riferimento;
- 2) guadagna, passando attraverso la cavità RF, sempre la stessa quantità di energia  $E_p$
- 3) entra in cavità sempre con la stessa fase rispetto alla tensione accelerante (**fase sincrona**) e vede sempre la stessa tensione accelerante.

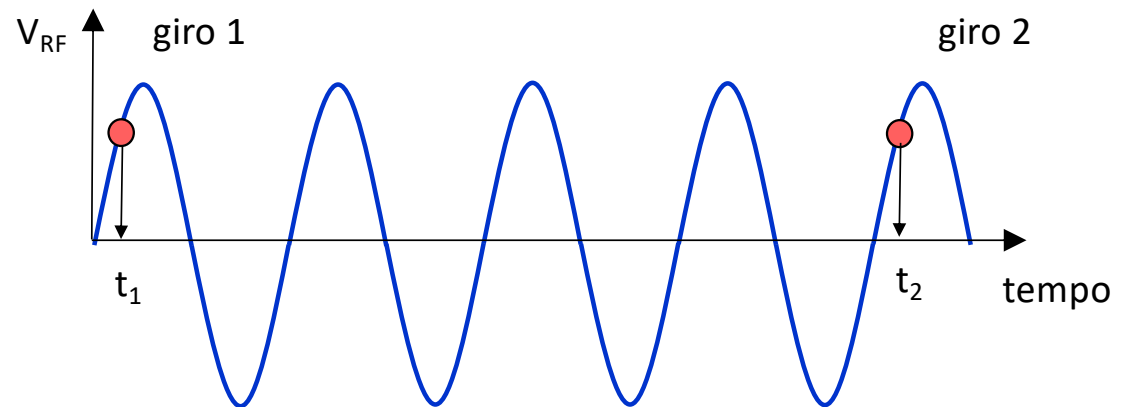

# PARTICELLE NON-SINCRONE

Il moto di una particella non sincrona, ("vicina" in posizione ed energia) alla particella sincrona può essere descritto utilizzando le seguenti quantità:

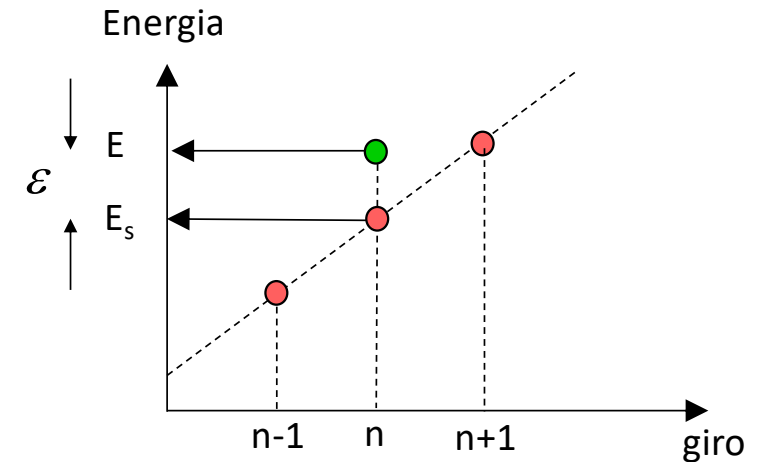
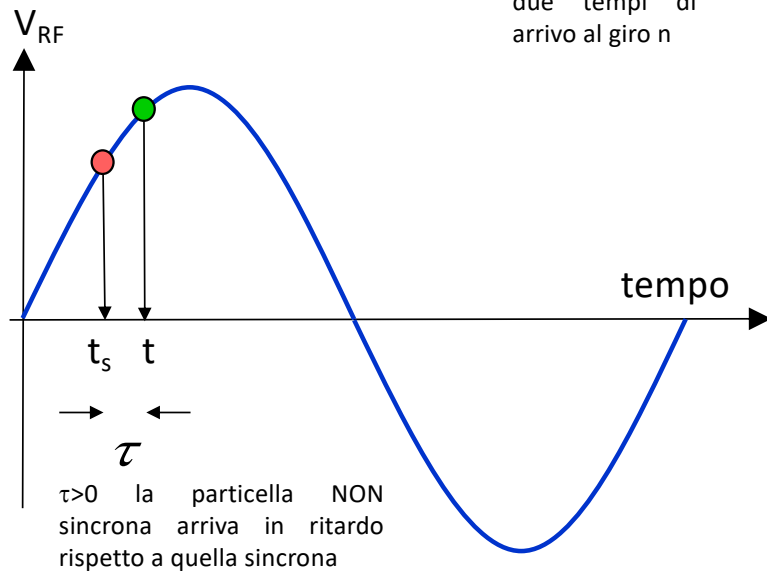
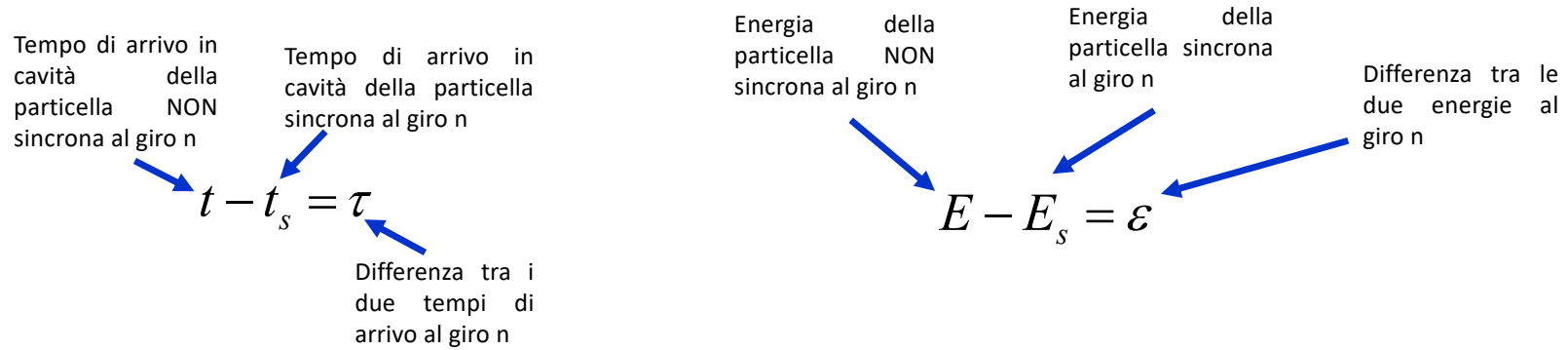

# OSCILLAZIONI DI SINCROTRONE

Consideriamo una particella **NON sincrona** che entra in cavità in ritardo rispetto a quella sincrona.

La **tensione accelerante vista dalla particella è maggiore** di quella vista dalla particella sincrona.

A questa maggiore accelerazione corrisponde un aumento di velocità e, quindi, al giro successivo la particella NON sincrona avrà **recuperato parte del suo "svantaggio"** rispetto a quella sincrona e si troverà più vicina. Viceversa se una particella arriva prima della particella sincrona in cavità vede una tensione in cavità minore e al giro successivo arriverà un po' più in ritardo.

In altre parole **le particelle NON sincrona oscillano stabilmente intorno alla particella (o fase) sincrona** (Principio della stabilità di fase.) Le oscillazioni delle particelle non sincrona intorno alla fase sincrona vengono dette **OSCILLAZIONI DI SINCROTRONE**. La corrispondente frequenza viene detta **FREQUENZA DI SINCROTRONE**

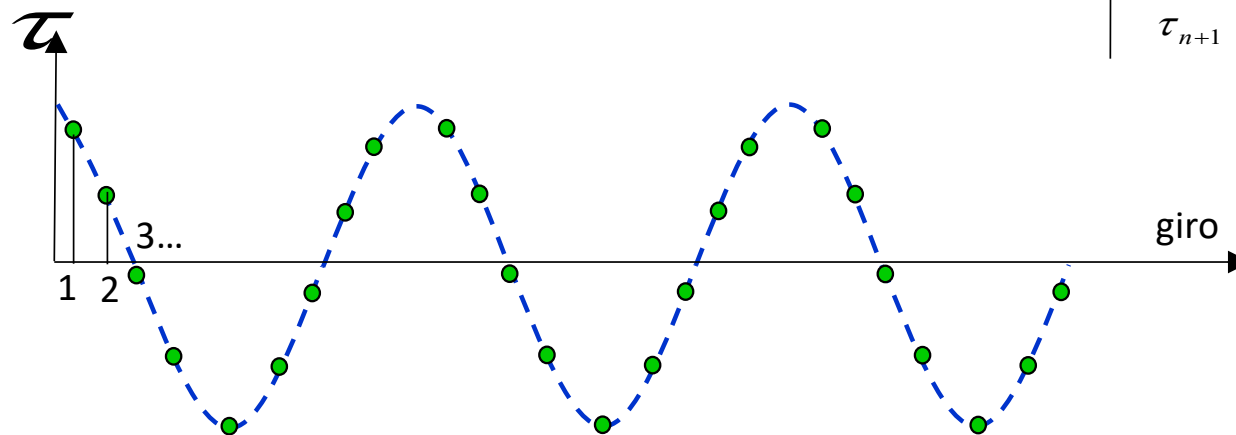
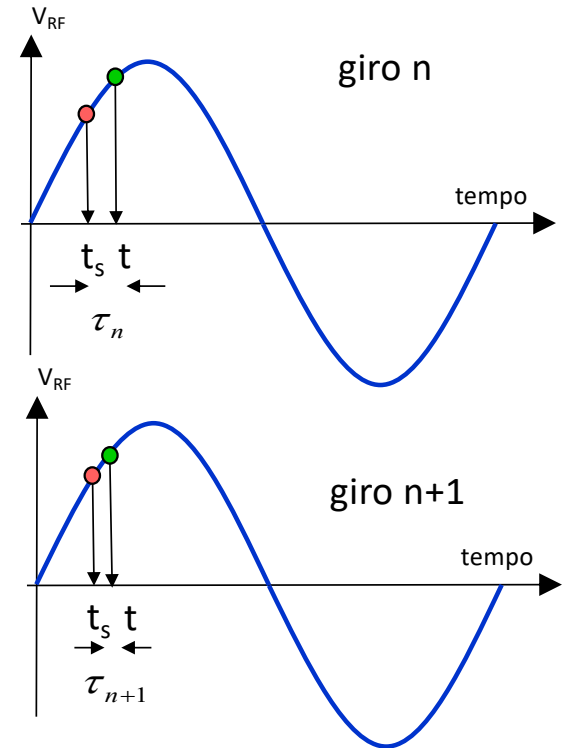

# OSCILLAZIONI DI SINCROTRONE NELLO SPAZIO DELLE FASI

Alle oscillazioni in posizione attorno alla particella sincrona corrispondono oscillazioni in energia.

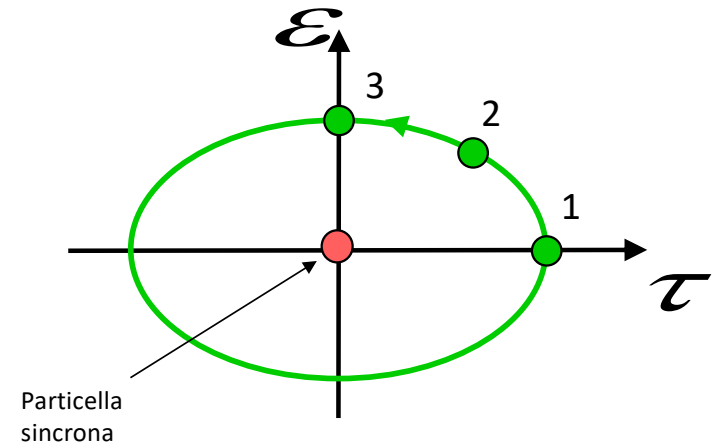
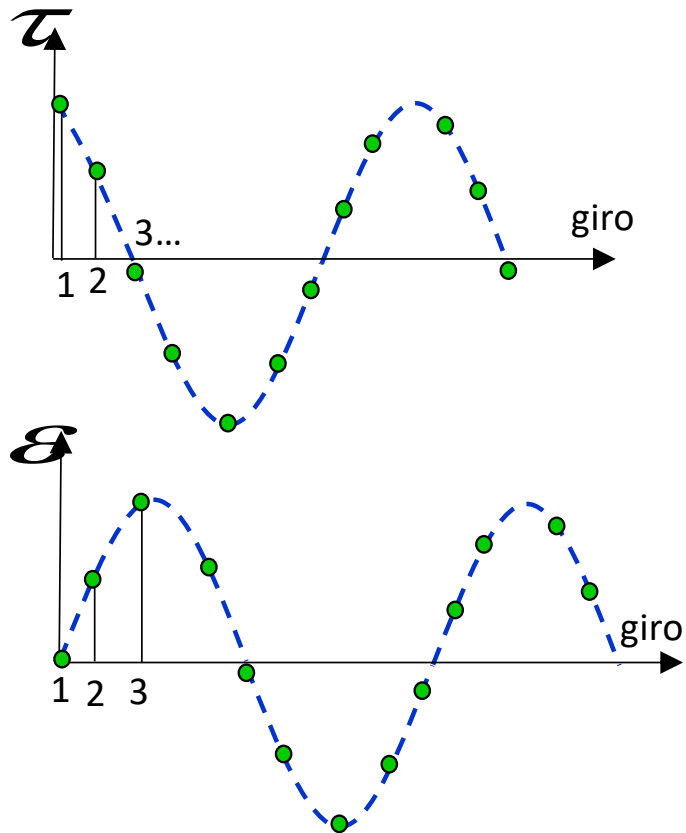

Nel piano  $(\tau, \epsilon)$  detto spazio delle fasi longitudinale una particella non sincrona descrive una ellisse che percorre con una frequenza pari proprio alla frequenza di sincrotrone.

# LUNGHEZZA DEL PACCHETTO DI PARTICELLE

In un certo istante le  $N$  *particelle* che compongono il pacchetto sono *distribuite intorno alla particella sincrona* e oscillano intorno a questa stabilmente e con la stessa frequenza *descrivendo delle ellissi* di area diversa nello spazio delle fasi.

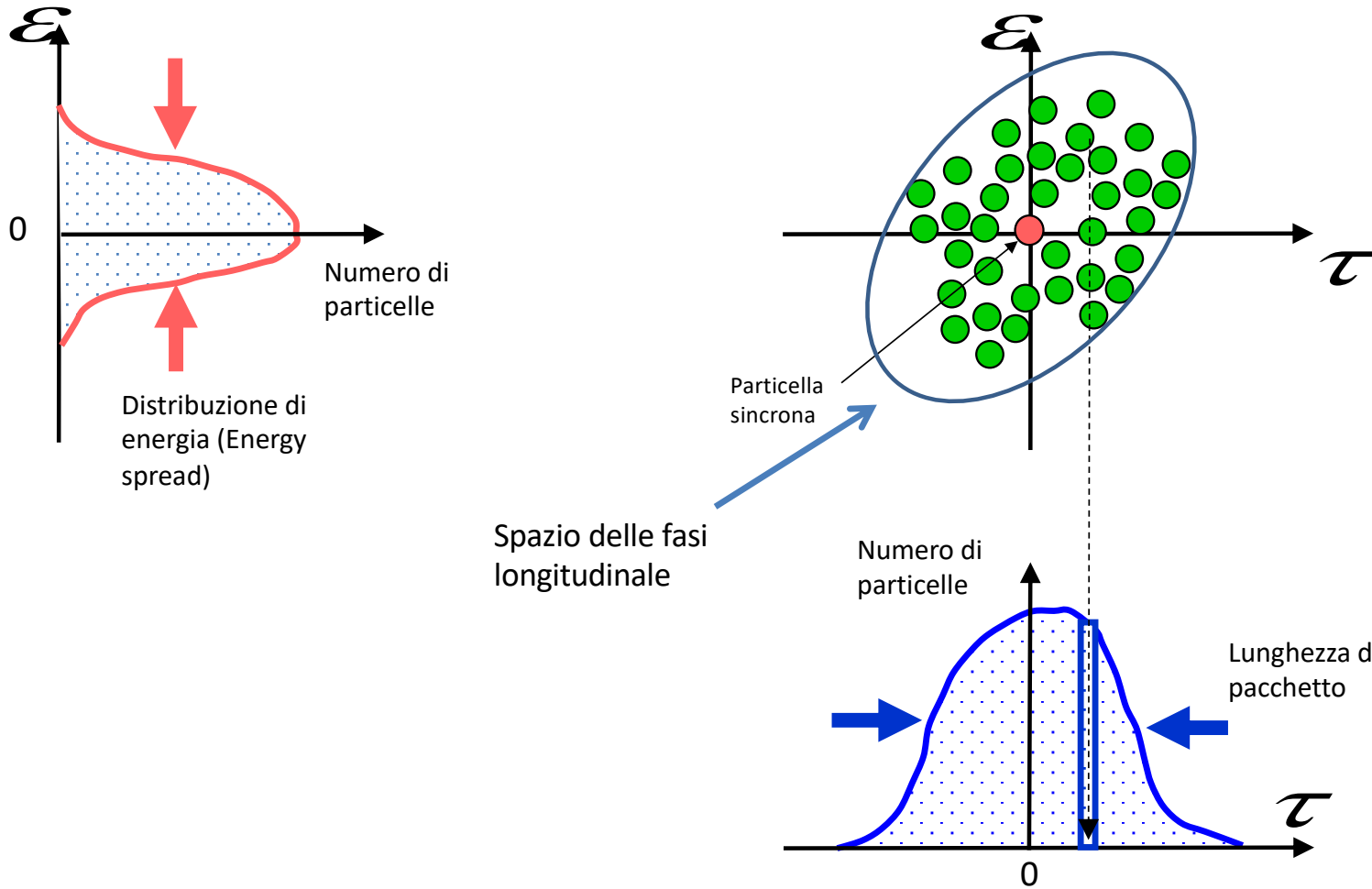

L'area dell'ellisse che racchiude tutte le particelle si chiama **emittanza** (in questo caso "longitudinale")

# LORENTZ FORCE: ACCELERATION AND FOCUSING

Particles are accelerated through electric field and are bended and focalized through magnetic field.  
 The basic equation that describe the acceleration/bending /focusing processes is the **Lorentz Force**.

$\vec{p}$  = momentum  
 $m$  = mass  
 $\vec{v}$  = velocity  
 $q$  = charge

$$\frac{d\vec{p}}{dt} = q(\vec{E}_{acc} + \vec{v} \times \vec{B})$$

## ACCELERATION

To accelerate, we need a force in the direction of motion

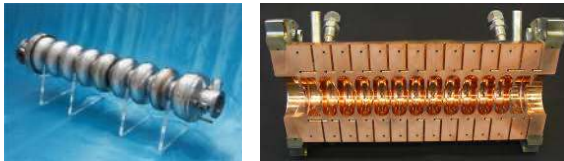
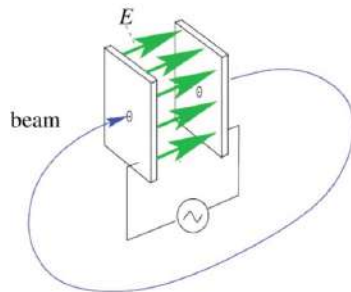

Longitudinal Dynamics

## BENDING AND FOCUSING

2<sup>nd</sup> term always perpendicular to motion => no energy gain

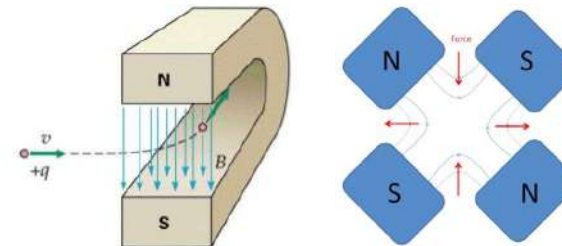

Transverse Dynamics

# TRANSVERSE PHASE SPACE AND EMITTANCE

Similarly to what we have in the longitudinal plane also in the transverse plane the particles perform oscillations (called **betatron oscillations**) due to the force provided by quadrupoles.

At a certain point in the machine each particle has a given transverse position and angle with respect to the direction of propagation

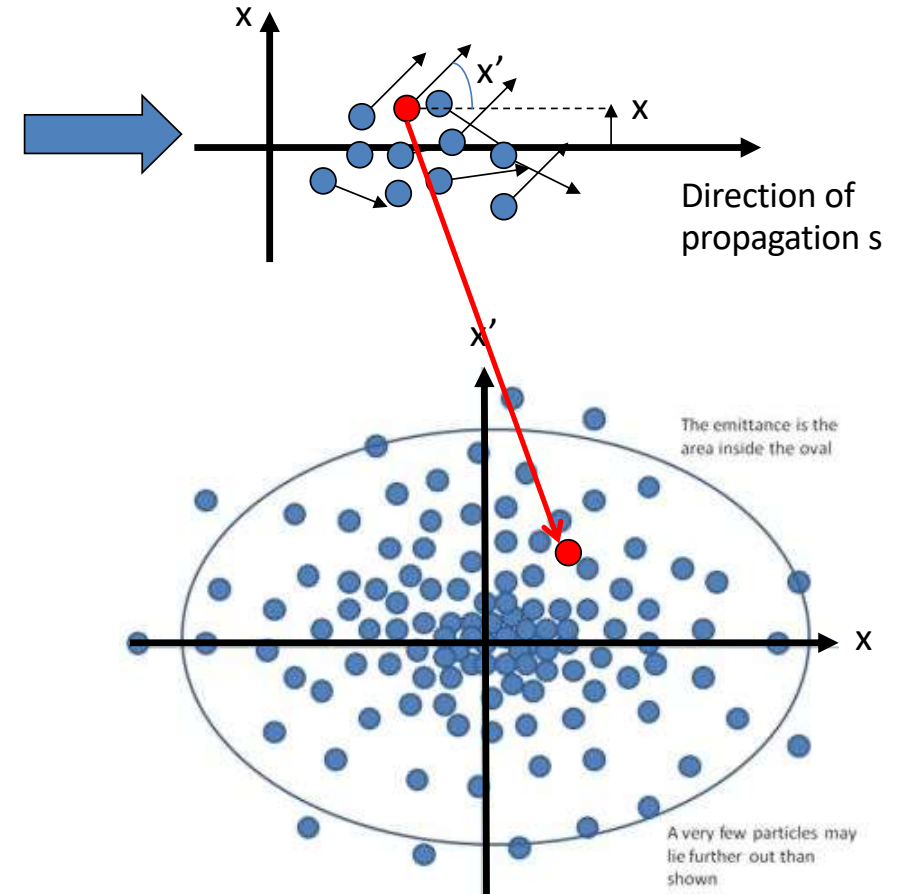
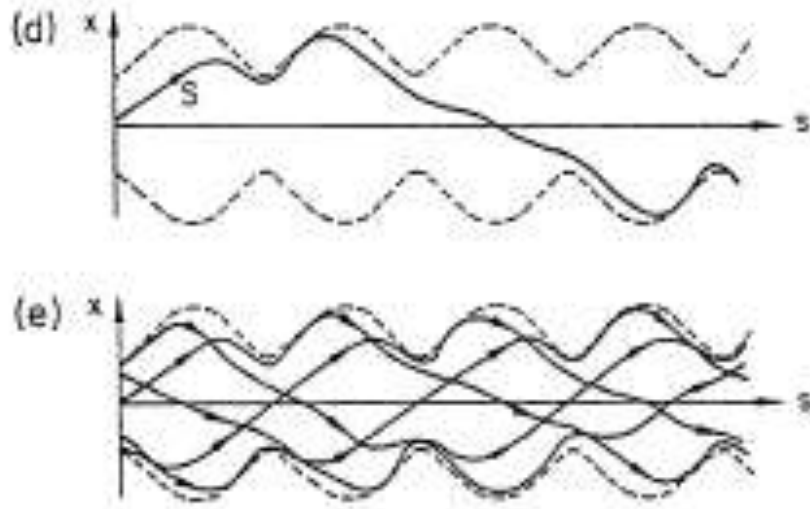

The area in the phase space occupied by the bunch is called **transverse emittance**

# WHAT CAN PARTICLE ACCELERATORS DO?

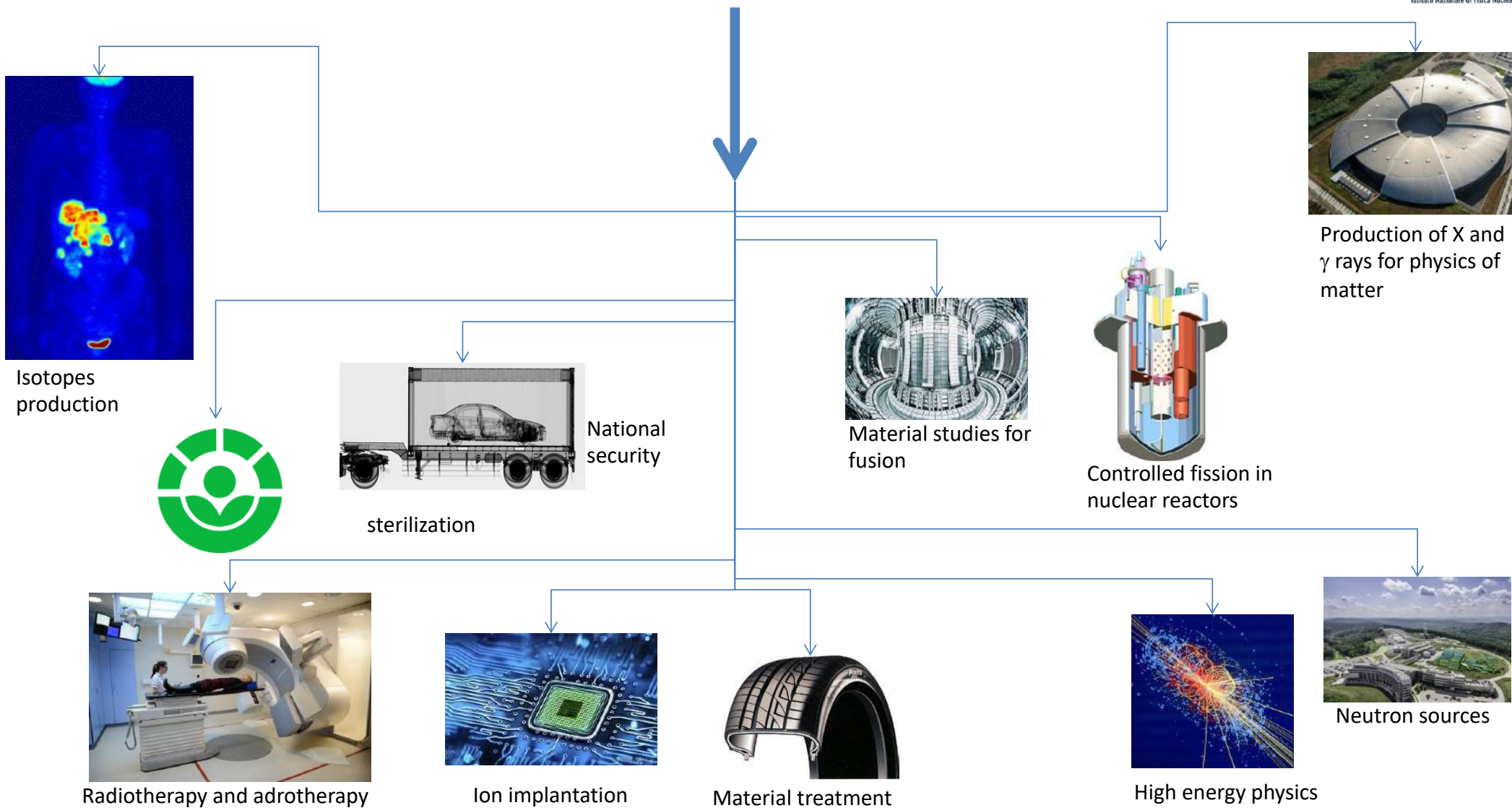

# APPLICAZIONI MEDICHE: PRODUZIONE DI RADIOISOTOPI

**Produzione di radioisotopi:** protoni da 7-100 MeV accelerati con ciclotroni o linac (50 isotopi, utilizzati per diagnostica e trattamento sono prodotti con acceleratori)

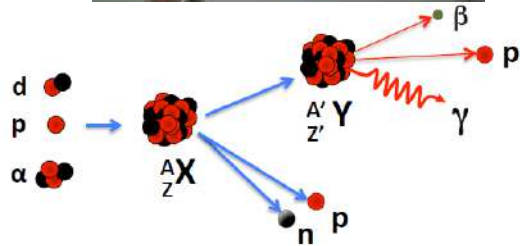

**PET:** diagnostica medica (oncologica)

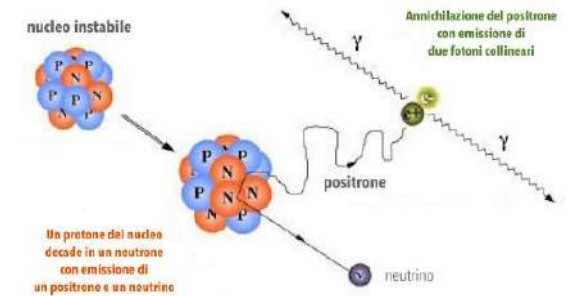
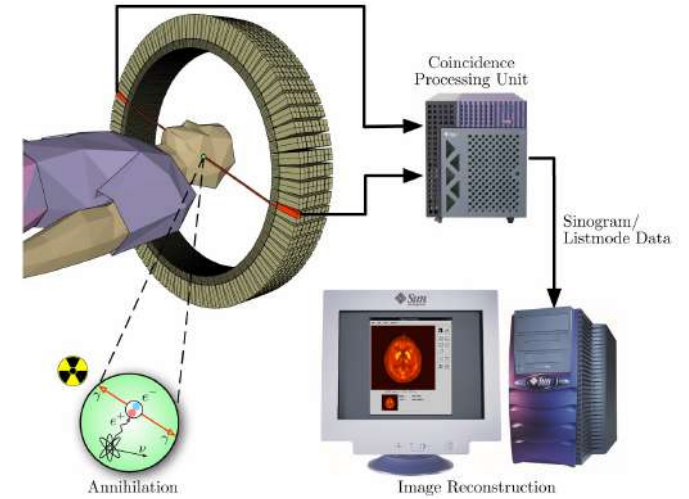
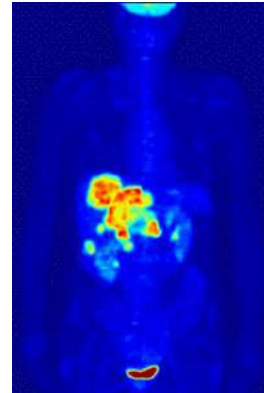

# APPLICAZIONI MEDICHE: RADIOTERAPIA

Si irradiano le masse tumorali con fasci di **raggi X** o **elettroni**

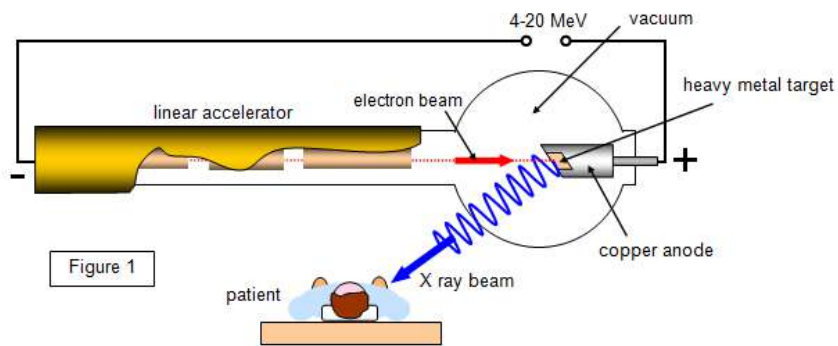

Foglio metallico per la produzione di raggi x

LINAC

Sistema di collimazione

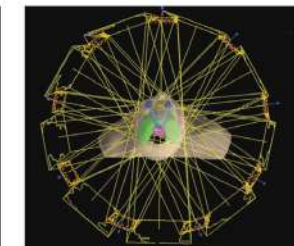
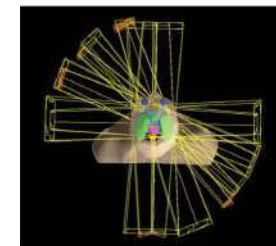
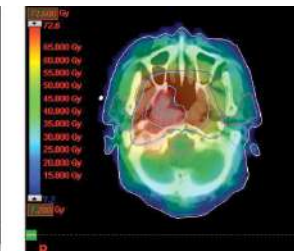
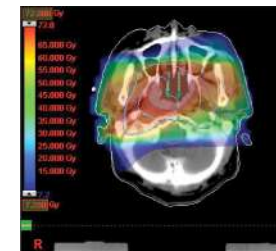
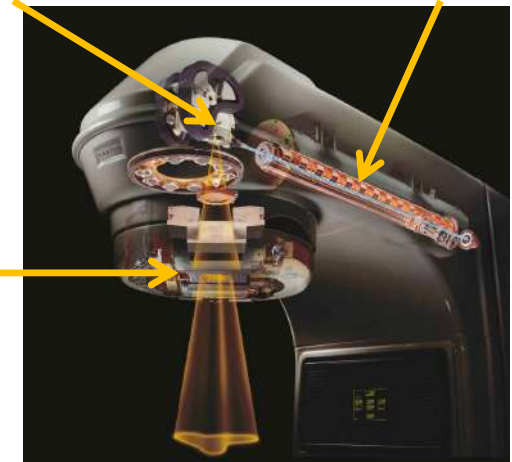

# APPLICAZIONI MEDICHE: ADROTERAPIA

Terapia antitumorale basata sull'irraggiamento con protoni e ioni pesanti (C).

E' più efficace e più localizzata (risonanza di Bragg) rispetto a quella basata su elettroni o raggi X

Centri in funzione: CNAO a Pavia, PSI a Zurigo, Loma Linda in California, Giappone,...

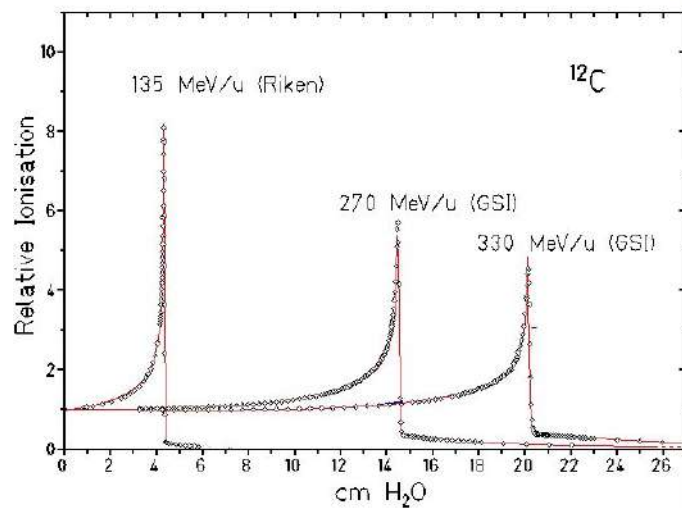
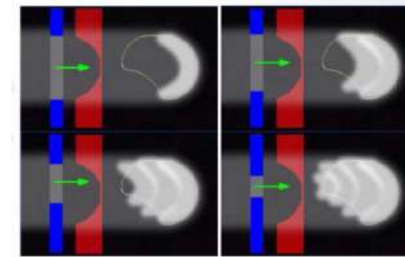
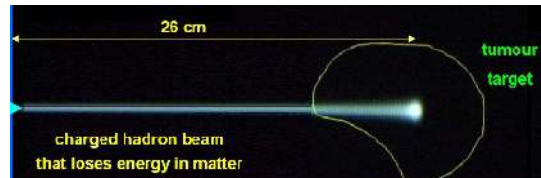
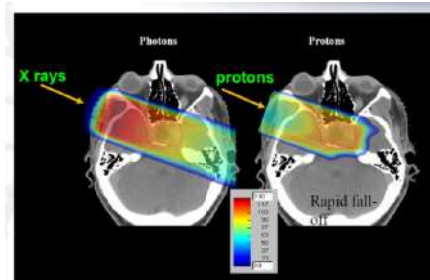
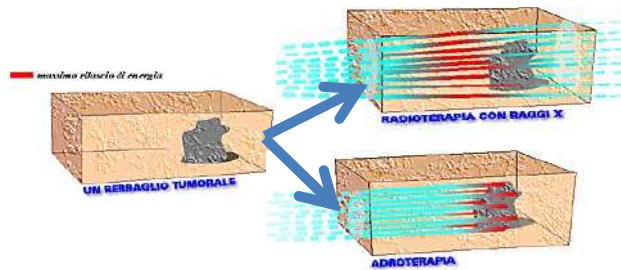

Comparison of the depth dose profiles

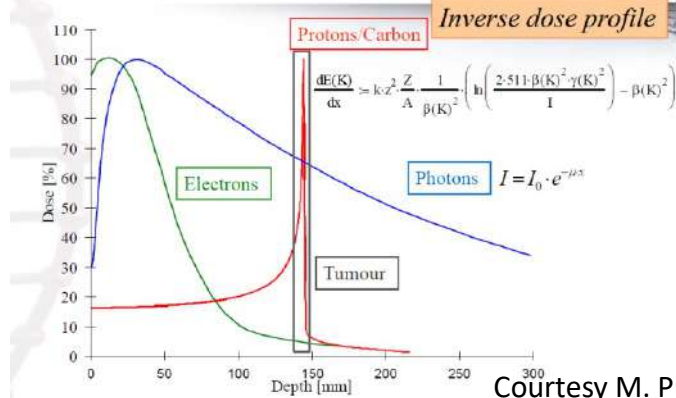

Courtesy M. Pullia

# APPLICAZIONI INDUSTRIALI

## Cargo Scan con raggi X

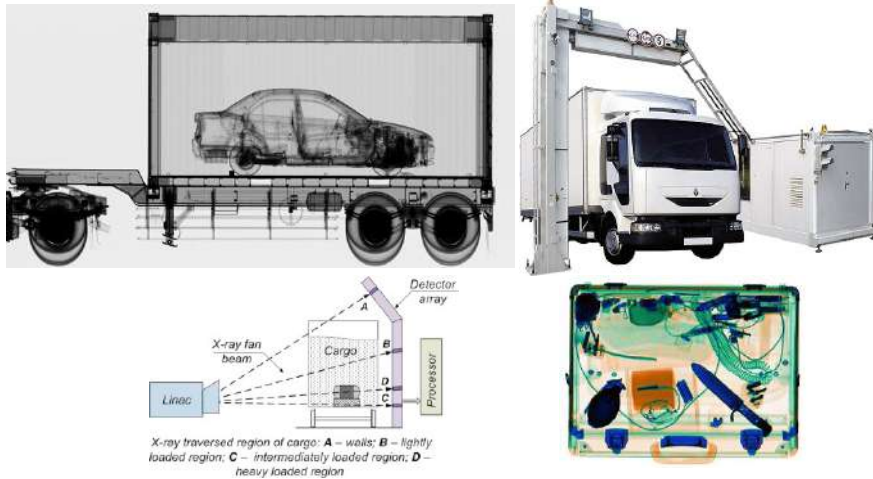

## Sterilizzazione e irradiazione di cibi per conservazione (“pastorizzazione fredda”)



## Trattamento di materiali polimerici: cross-linking

Tali trattamenti industriali aumentano le performances dei materiali in termini di resistenza al calore, elasticità, etc...



## Impiantazione ionica (semiconduttori)

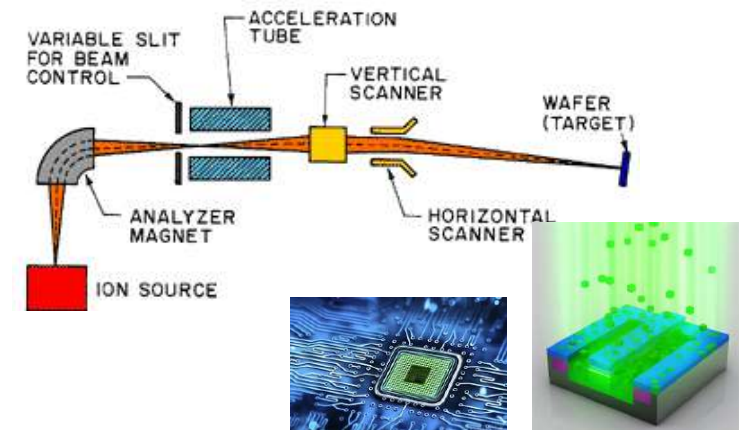

# PRODUZIONE DI ENERGIA CON ACCELERATORI

Un ADS (**Accelerator Driven System**) è un reattore nucleare a fissione **sottocritico** pilotato da un **acceleratore di protoni** ad alta energia (600 MeV- 1GeV). I **neutroni necessari** per sostenere il **processo di fissione** sono forniti dall'acceleratore di particelle

Vantaggi:

- Utilizza **torio** come **combustibile**, molto più abbondante dell'uranio e del plutonio
- breve vita dei prodotti di scarto** (dell'ordine dei 100 anni contro le centinaia di migliaia di anni dei reattori attuali).
- reattore **intrinsecamente sicuro** (**fissione controllata**)

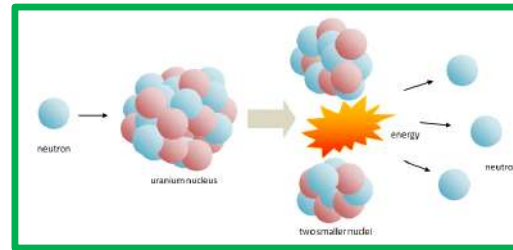
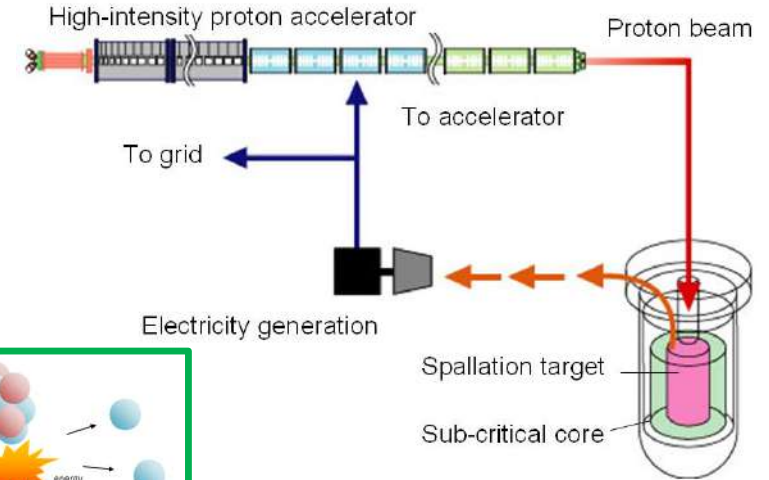

Proceedings of Linear Accelerator Conference LINAC2010, Tsukuba, Japan

## PROTON LINAC FOR ADS APPLICATION IN CHINA

Shinian Fu, Shouxian Fang, Jiuqing Wang  
 IHEP, Institute of High Energy Physics, Beijing 100049, China  
 Xialing Guan  
 CIAE, China Institute of Atomic Energy, Beijing 102413, China

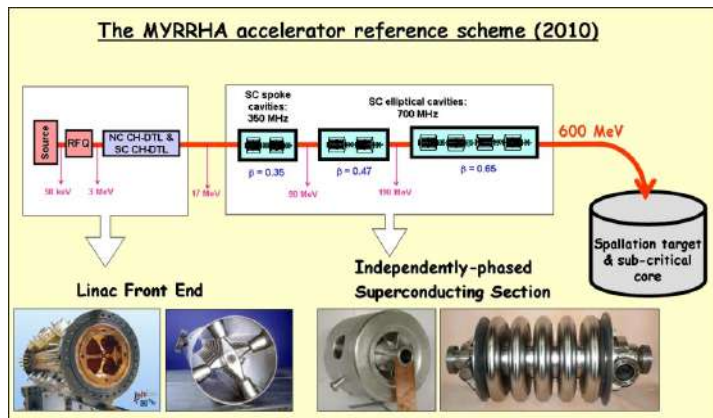

Alcuni esperimenti di laboratorio e molti studi teorici hanno dimostrato la possibilità teorica di tale impianto. **Carlo Rubbia**, è stato uno dei primi a concepire un progetto di un reattore subcritico, il cosiddetto "**amplificatore di energia**". Nel 2012 gli scienziati e gli ingegneri del CERN hanno lanciato l'International Thorium Energy Committee (iThEC) un'organizzazione dedicata a perseguire questo obiettivo.

# TEST DI MATERIALI PER REATTORI A FUSIONE NUCLEARE

In un futuro reattore a fusione nucleare deuterio-trizio le reazioni di fusione generano un flusso di neutroni dell'ordine di  $10^{18} \text{ m}^{-2}\text{s}^{-1}$  con una energia di 14.1 MeV che collide contro le pareti interne del reattore

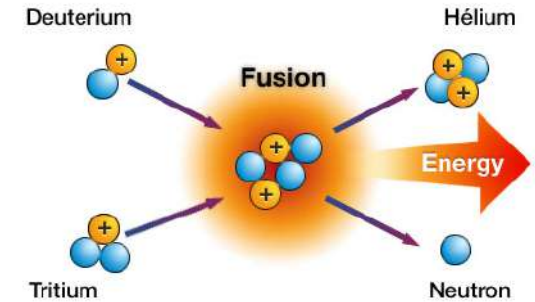

L'International Fusion Materials Irradiation Facility (IFMIF), è un impianto di test di materiali utilizzabili in un reattore di fusione. E' una sorgente di neutroni basata sul un acceleratore di deuterio che collidendo contro atomi di litio produce un flusso di neutroni analogo a quello previsto nella prima parete di un reattore a fusione.

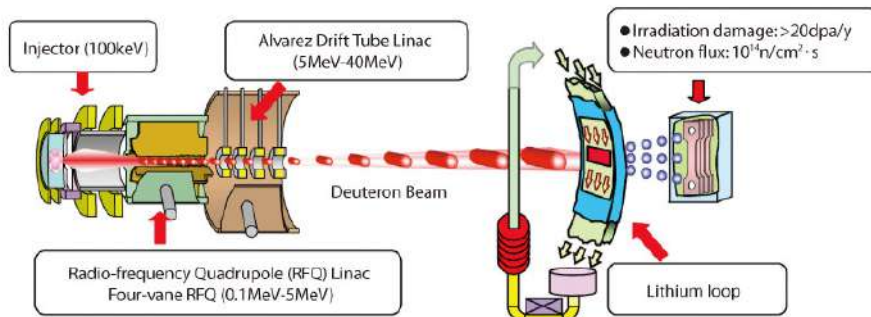
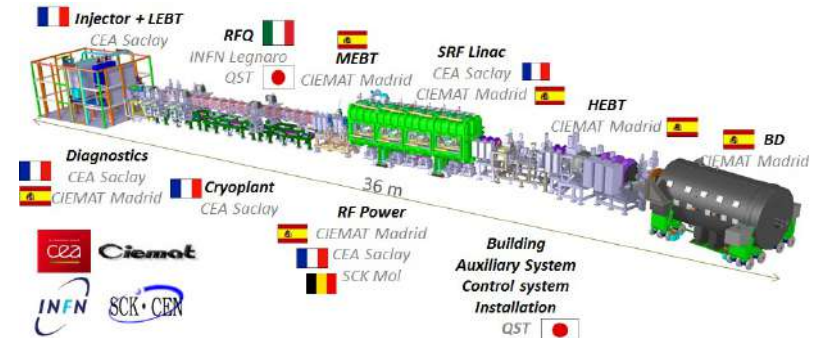

# ESPLORARE LA MATERIA CON RADIAZIONE DI LUNGHEZZA D'ONDA SEMPRE PIU' PICCOLA

Luce visibile:  
400-700 nm ( $\sim 10^{-7}$  m)

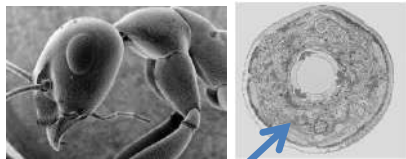

1-10  $\mu\text{m}$

Risoluzione 200 nm

Raggi X:  
0.01-10 nm ( $\sim 10^{-11}$ - $10^{-8}$  m)

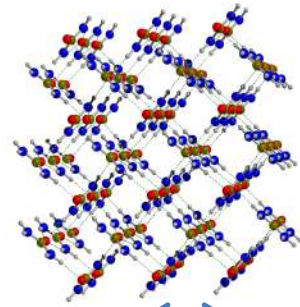

$\sim 10^{-10}$  m



FOTONI

Particelle accelerate  
<0.01 nm ( $< 10^{-11}$  m)

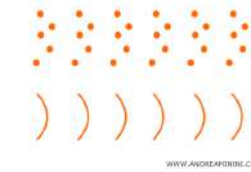
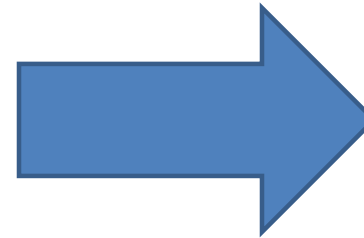
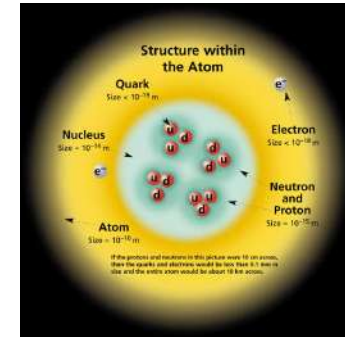

$$\lambda = h/p$$



PARTICELLE IN GENERALE

# LE PARTICELLE IN MOVIMENTO POSSONO EMETTERE RAGGI X?

Una particella carica ad una certa energia che viene fatta curvare tramite un magnete emette **radiazione elettromagnetica** (luce di sincrotrone).

Tale fenomeno è tanto più accentuato quanto più la particella è relativistica ( $\gamma > 1$ ) ovvero si muove a **velocità prossime a quella della luce**.

Ne consegue che **solo le macchine ad elettroni (particelle leggere)** emettono fotoni (eccetto LHC!).

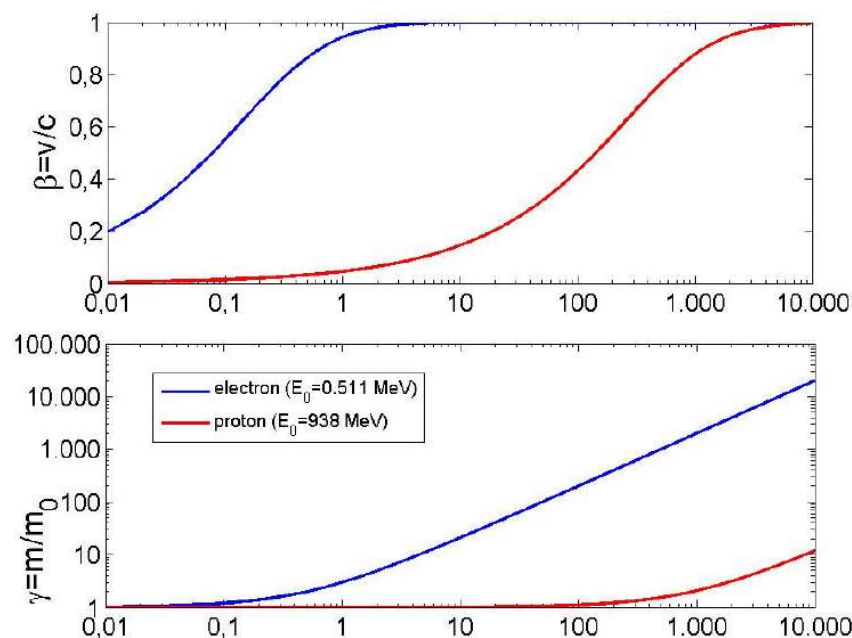
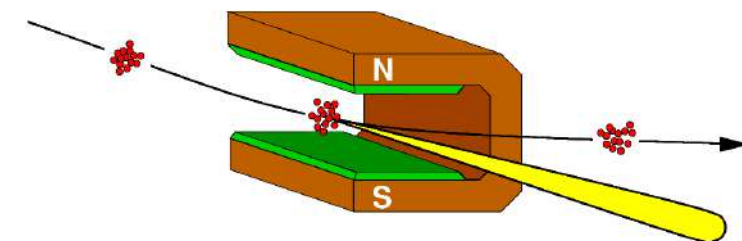
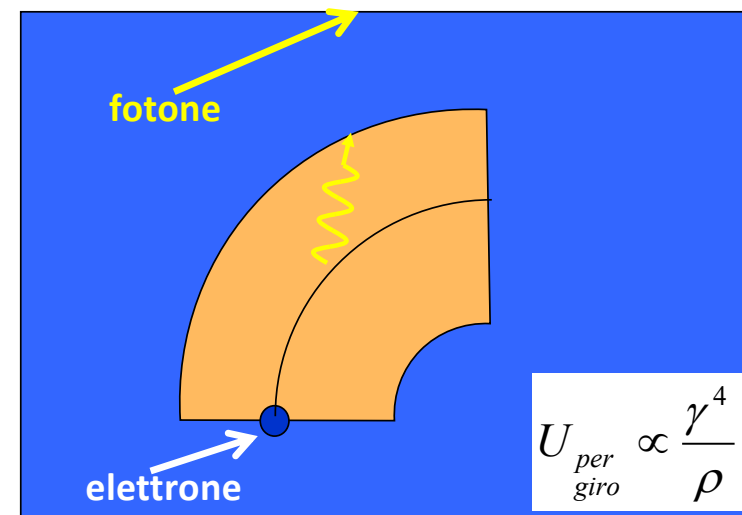

# RADIAZIONE DA PARTICELLE CARICHE ULTRARELATIVISTICHE

Campo elettrico

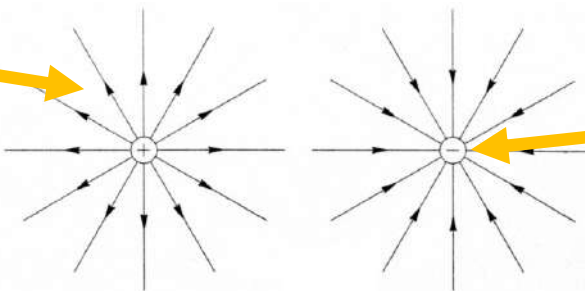

Carica ferma

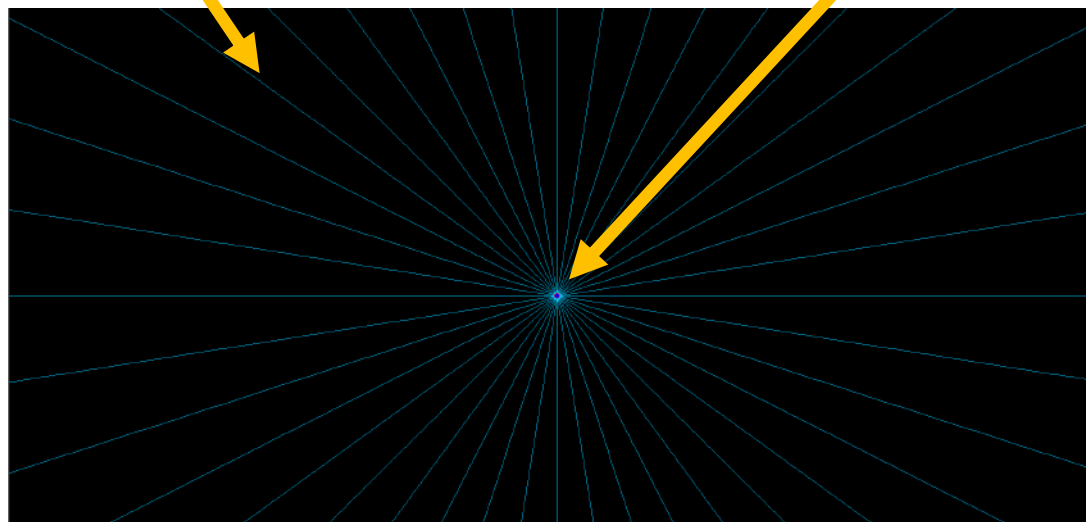

# RADIAZIONE DA PARTICELLE CARICHE ULTRARELATIVISTICHE

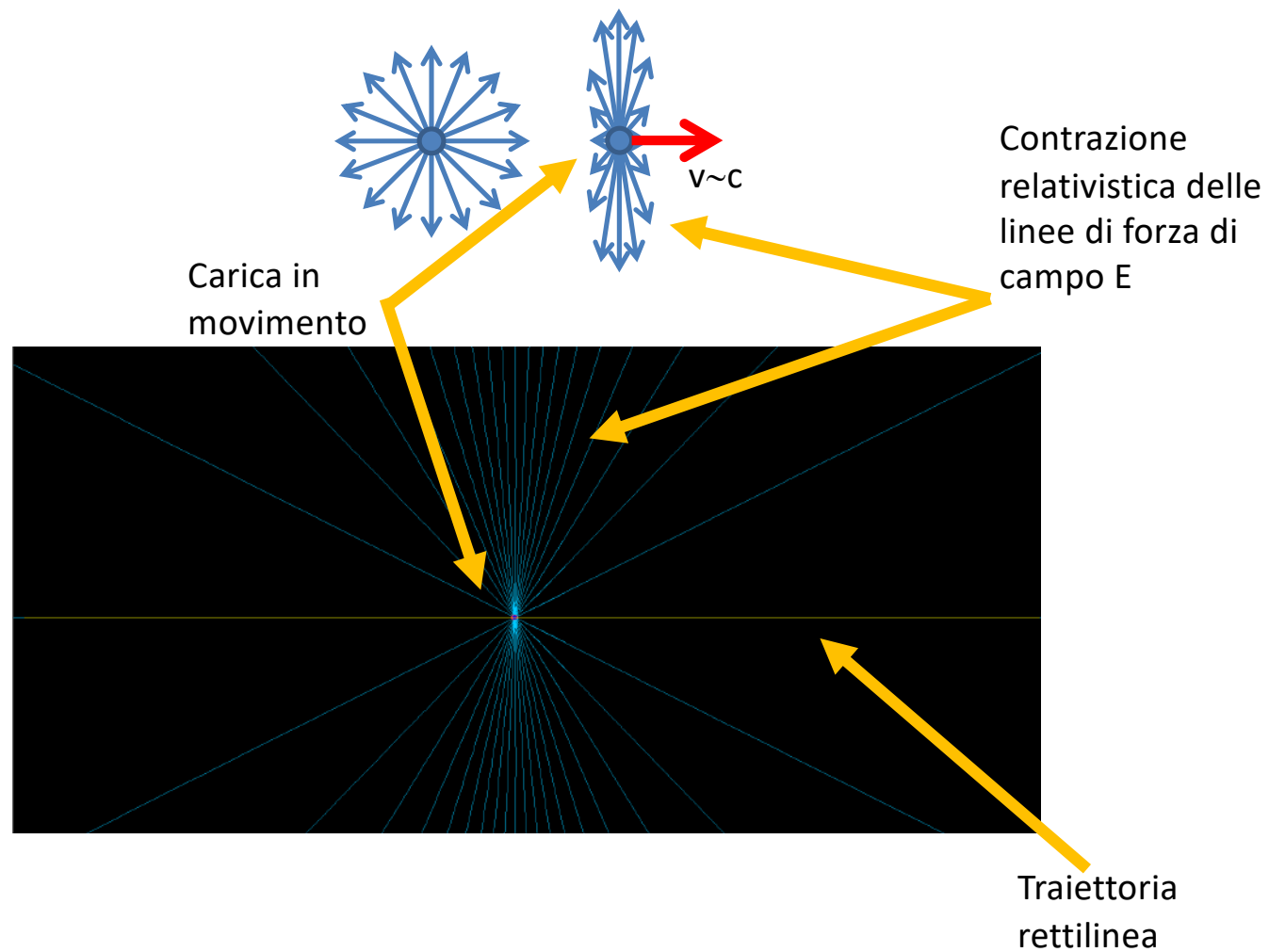

# RADIAZIONE DA PARTICELLE CARICHE ULTRARELATIVISTICHE

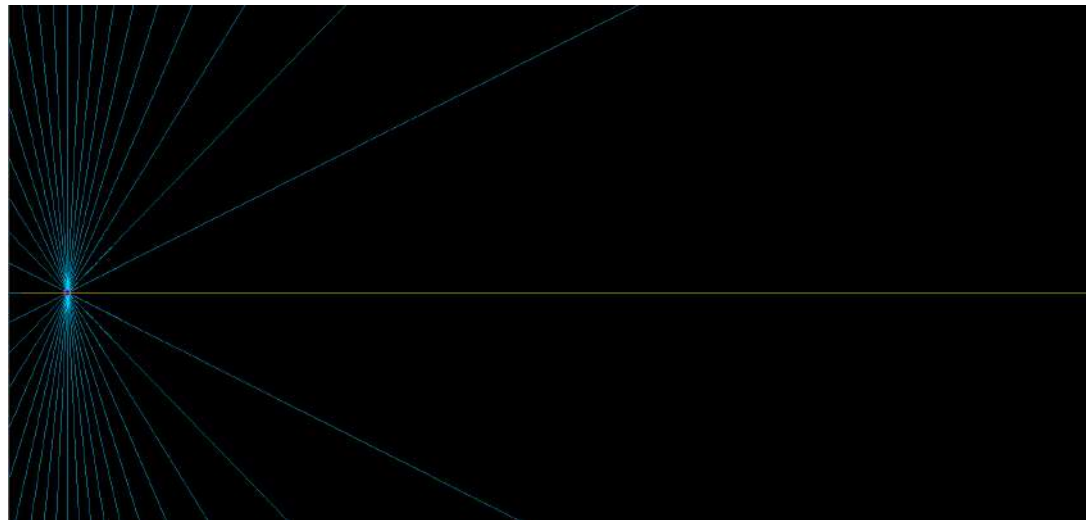

# RADIAZIONE DA PARTICELLE CARICHE ULTRARELATIVISTICHE

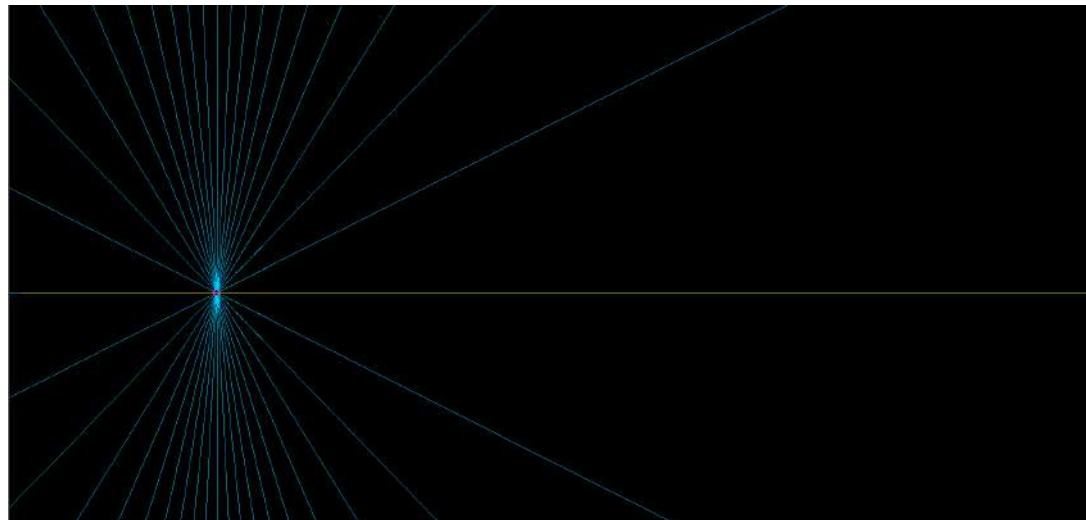

# RADIAZIONE DA PARTICELLE CARICHE ULTRARELATIVISTICHE

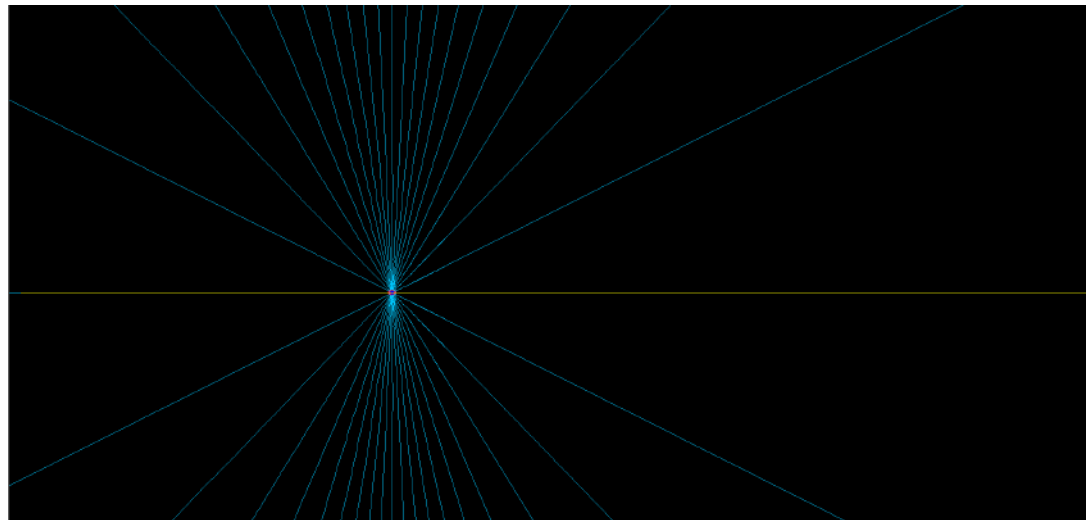

# RADIAZIONE DA PARTICELLE CARICHE ULTRARELATIVISTICHE

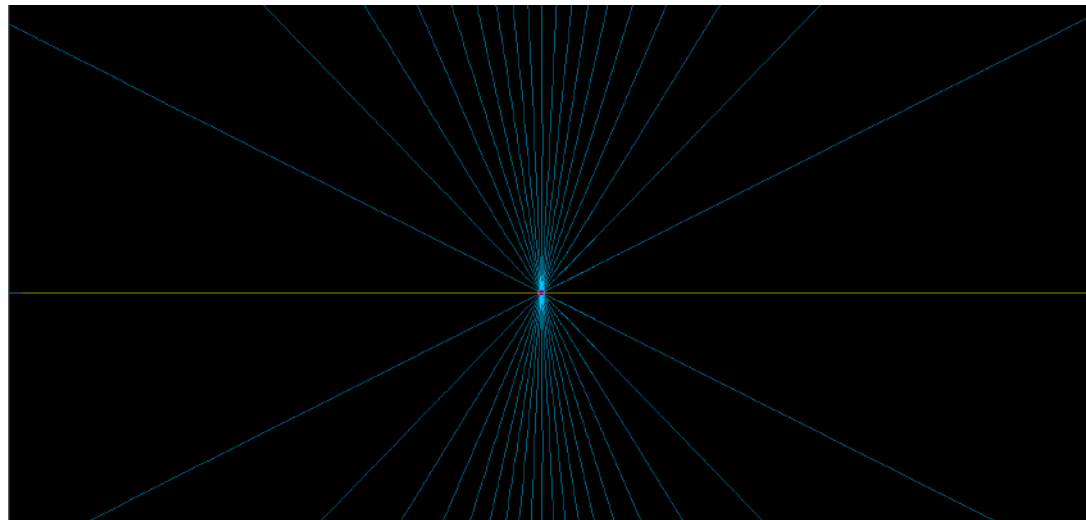

# RADIAZIONE DA PARTICELLE CARICHE ULTRARELATIVISTICHE

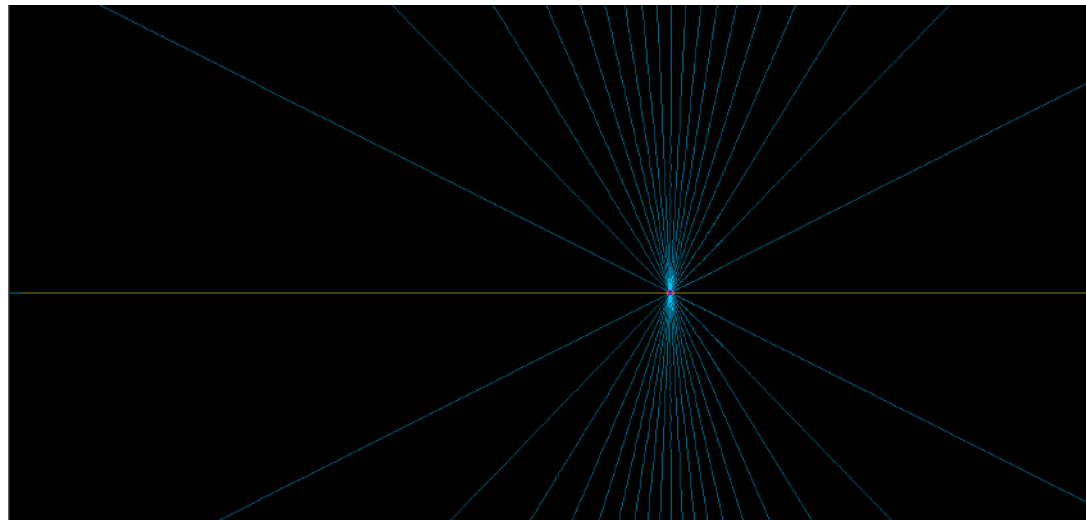

# RADIAZIONE DA PARTICELLE CARICHE ULTRARELATIVISTICHE

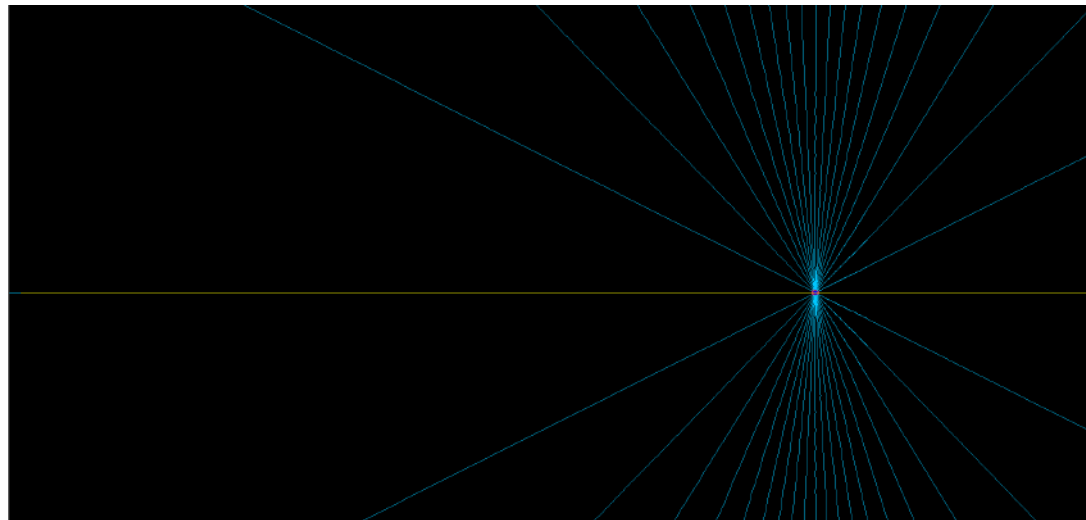

# RADIAZIONE DA PARTICELLE CARICHE ULTRARELATIVISTICHE

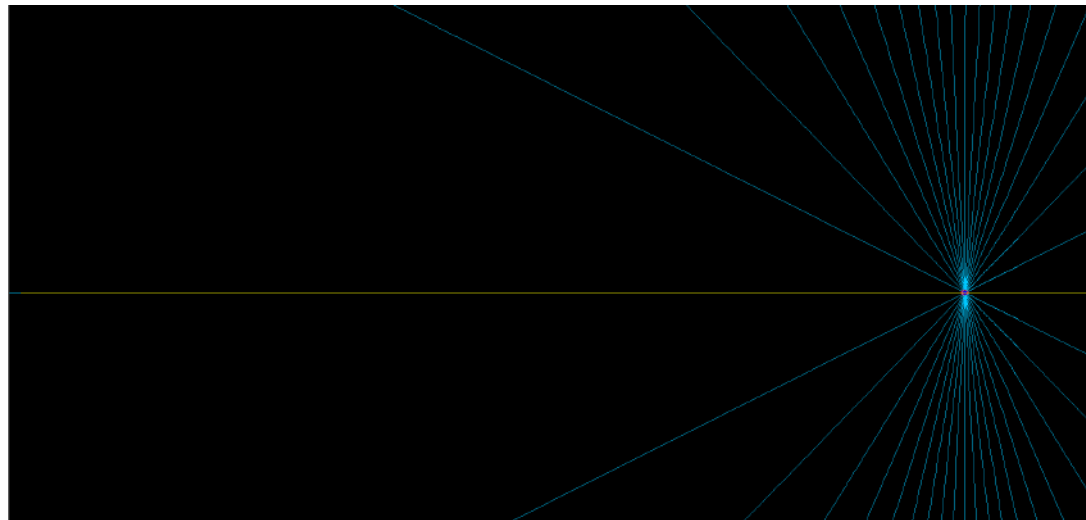

# RADIAZIONE DA PARTICELLE CARICHE ULTRARELATIVISTICHE: DIPOLO

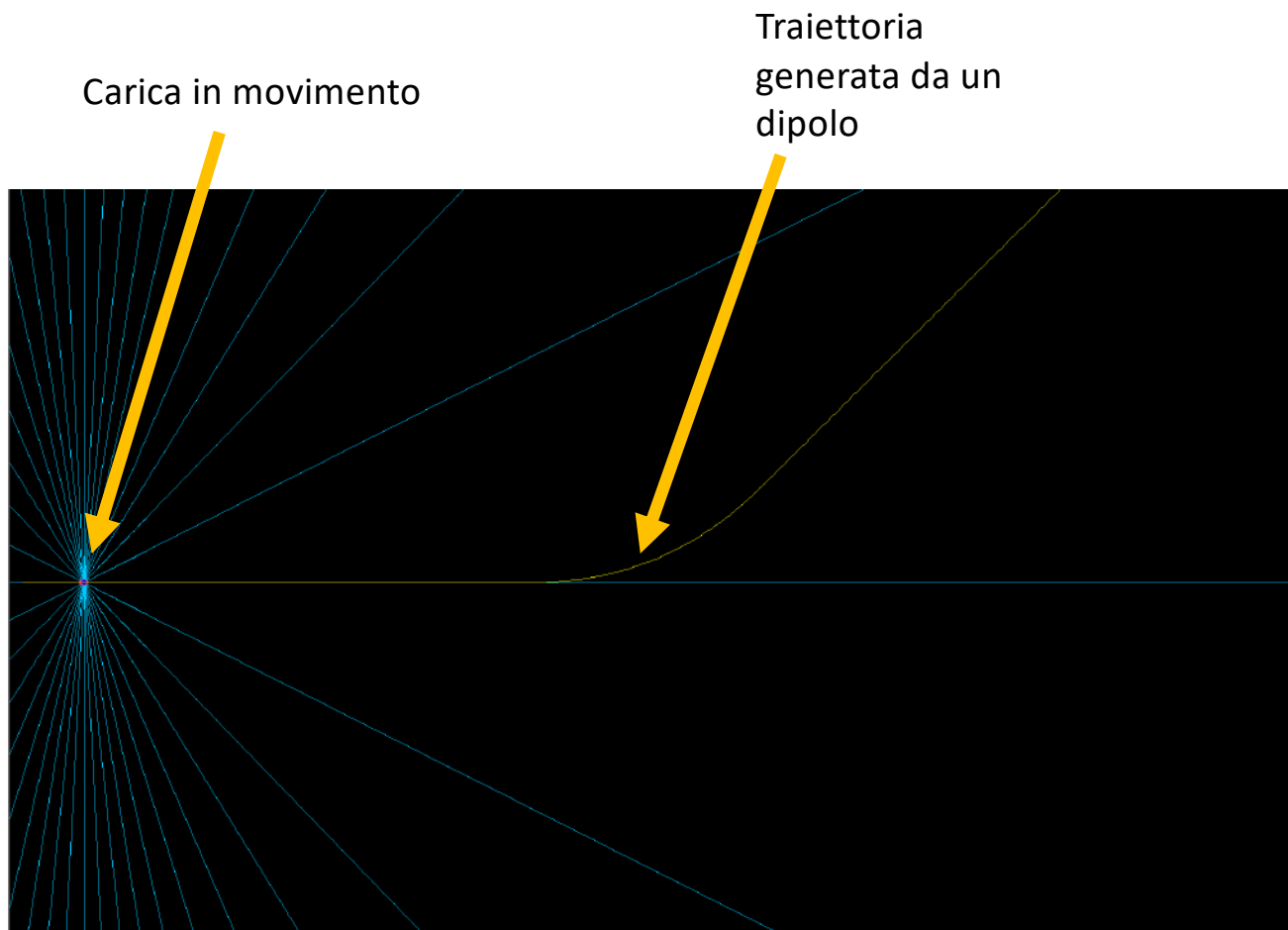

# RADIAZIONE DA PARTICELLE CARICHE ULTRARELATIVISTICHE: DIPOLO

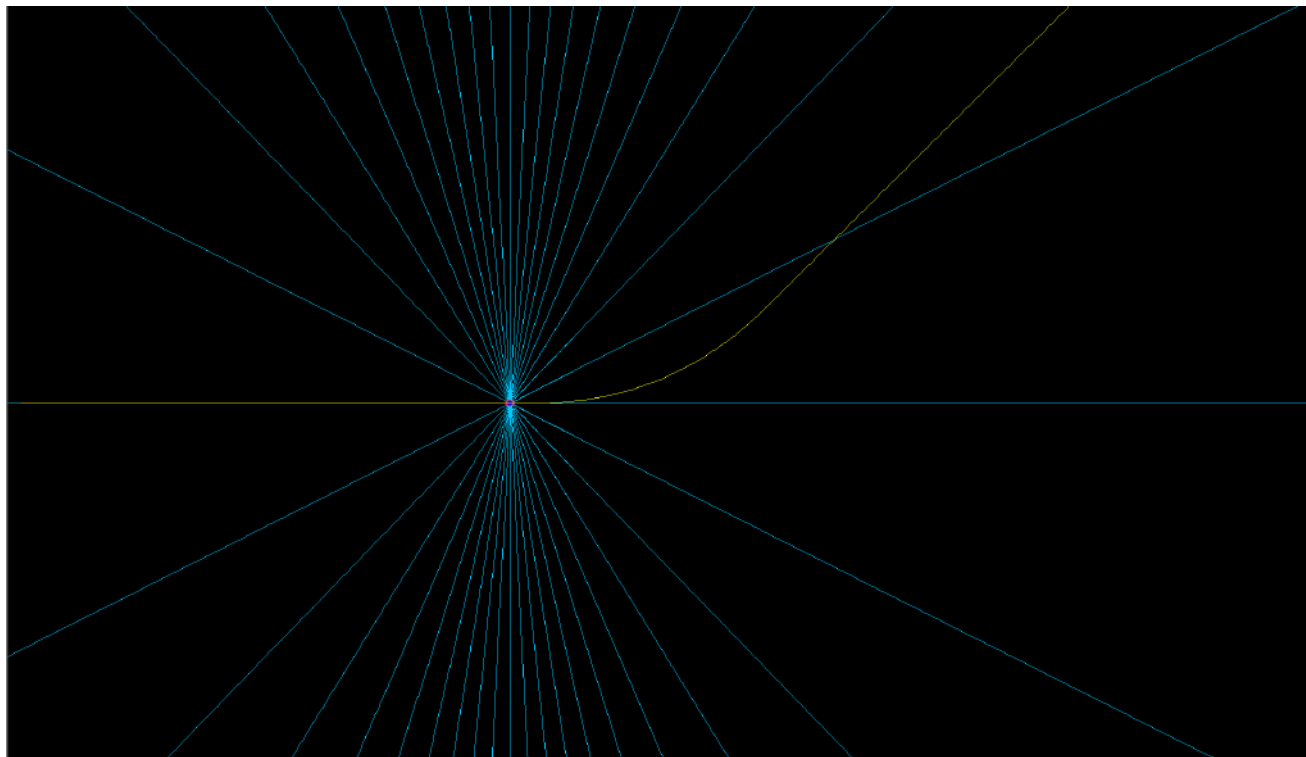

# RADIAZIONE DA PARTICELLE CARICHE ULTRARELATIVISTICHE: DIPOLO

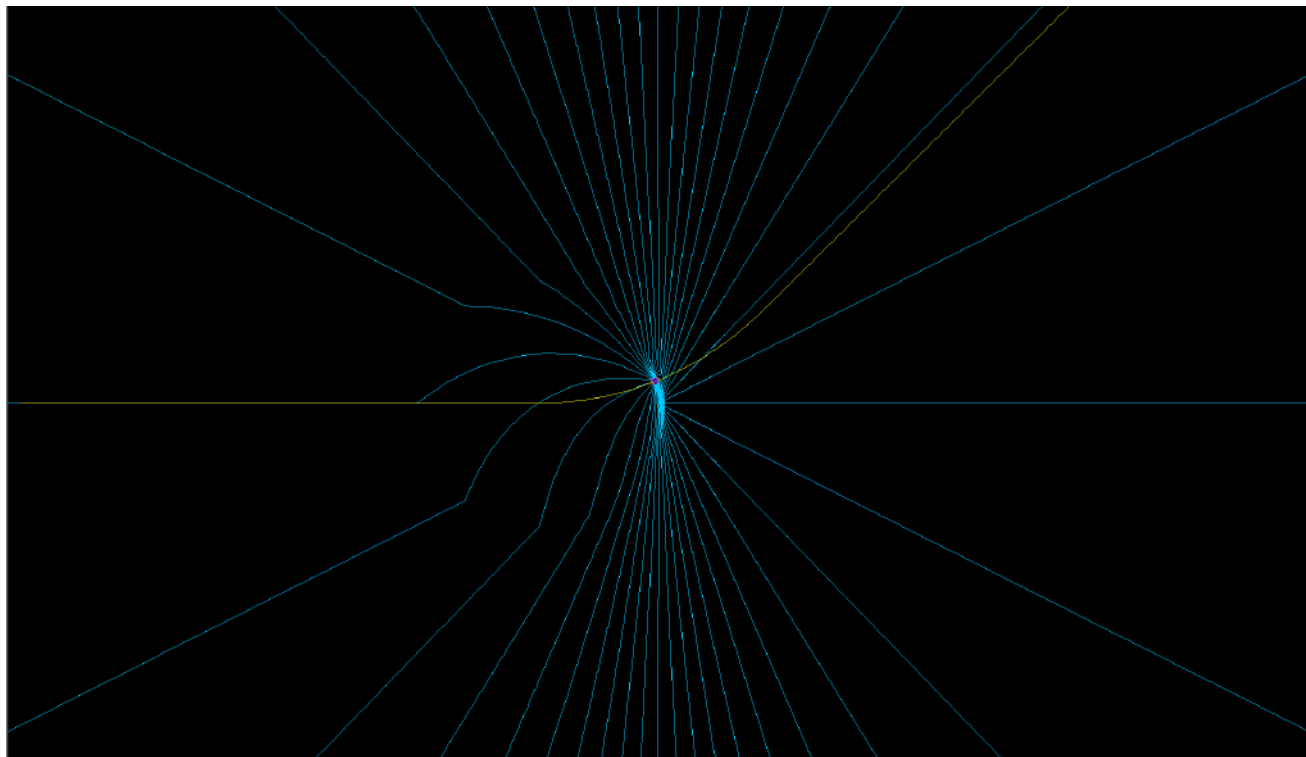

# RADIAZIONE DA PARTICELLE CARICHE ULTRARELATIVISTICHE: DIPOLO

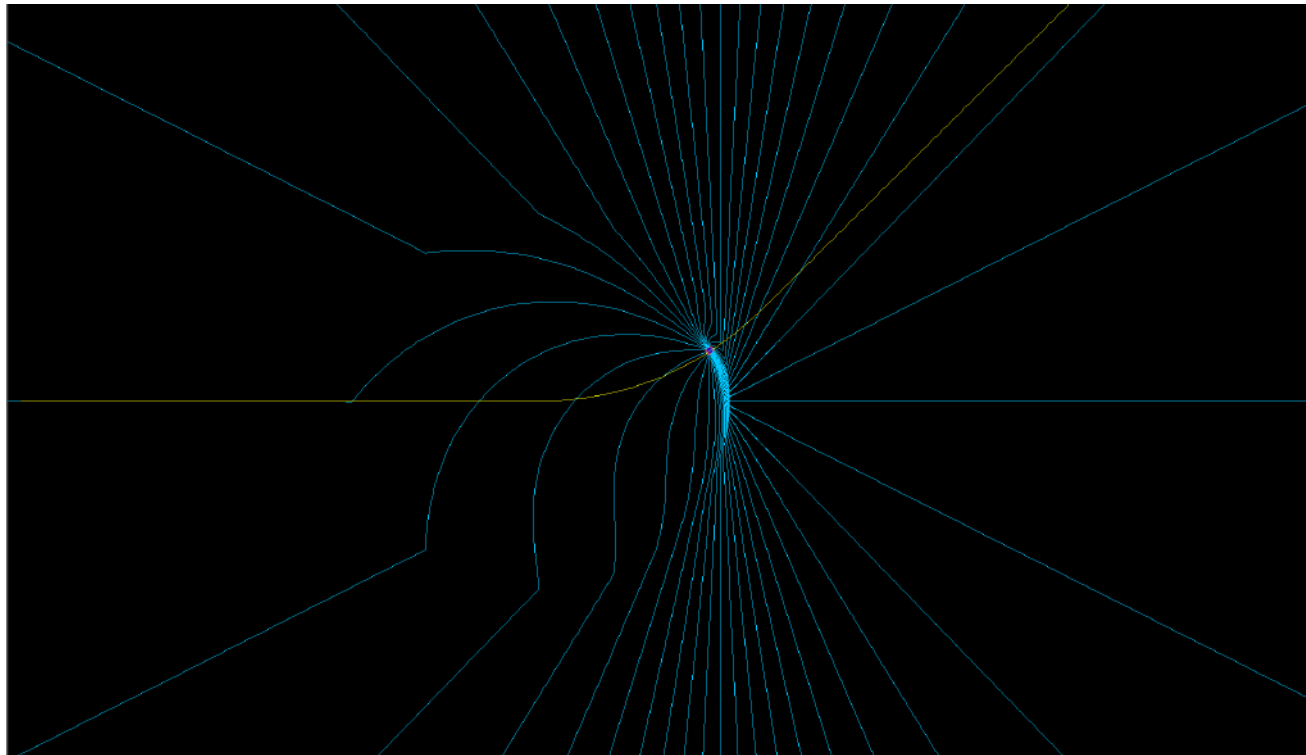

# RADIAZIONE DA PARTICELLE CARICHE ULTRARELATIVISTICHE: DIPOLO

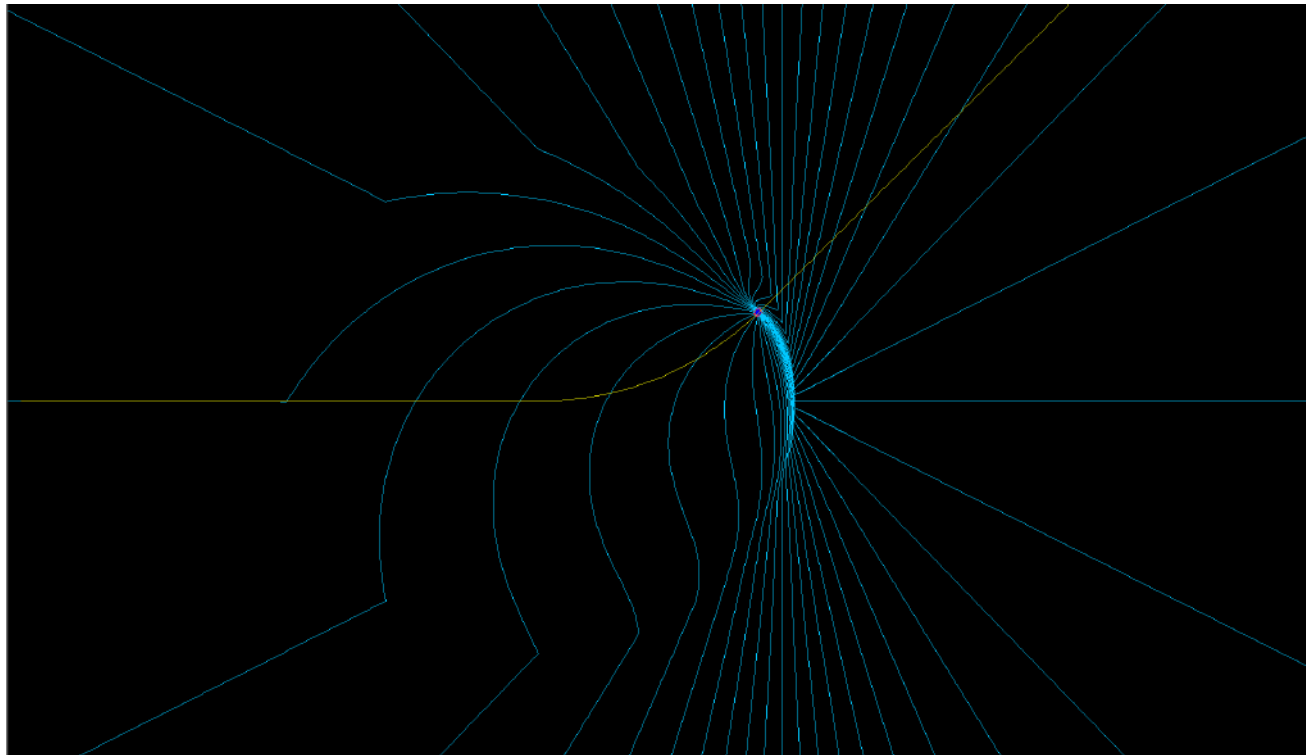

# RADIAZIONE DA PARTICELLE CARICHE ULTRARELATIVISTICHE: DIPOLO

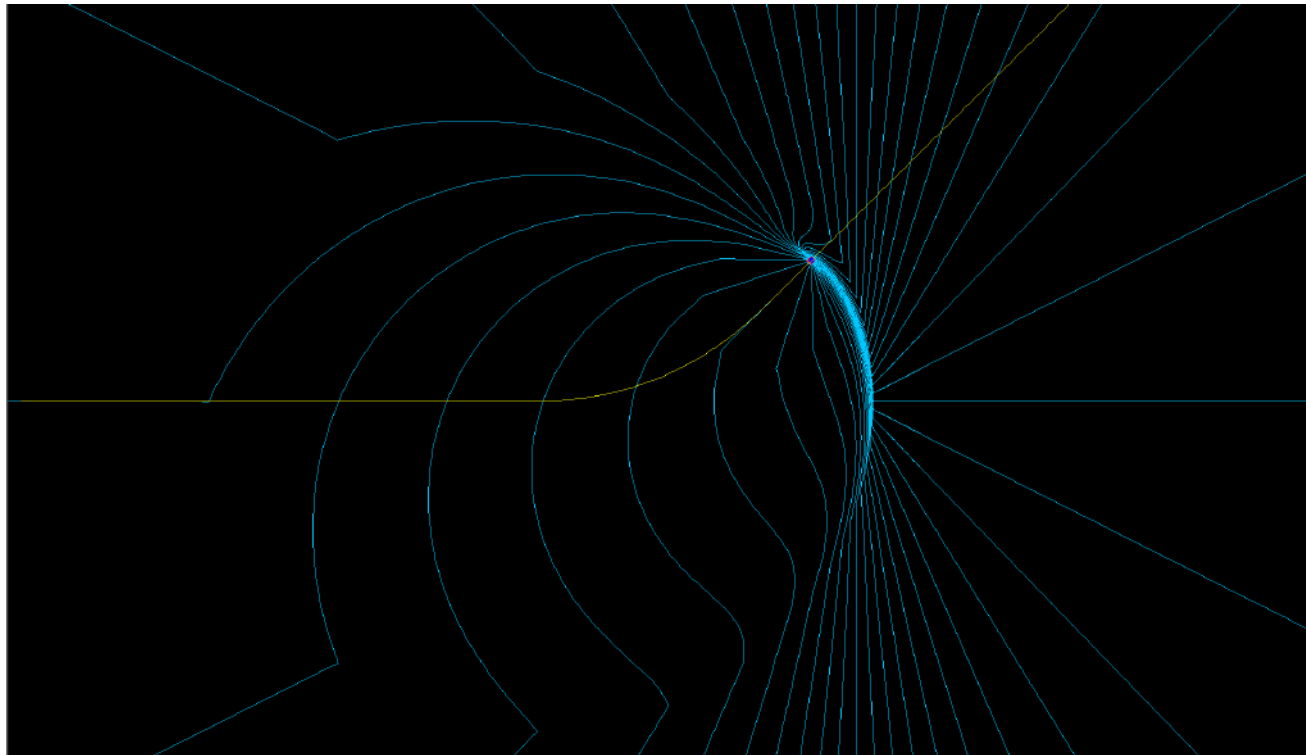

# RADIAZIONE DA PARTICELLE CARICHE ULTRARELATIVISTICHE: DIPOLO

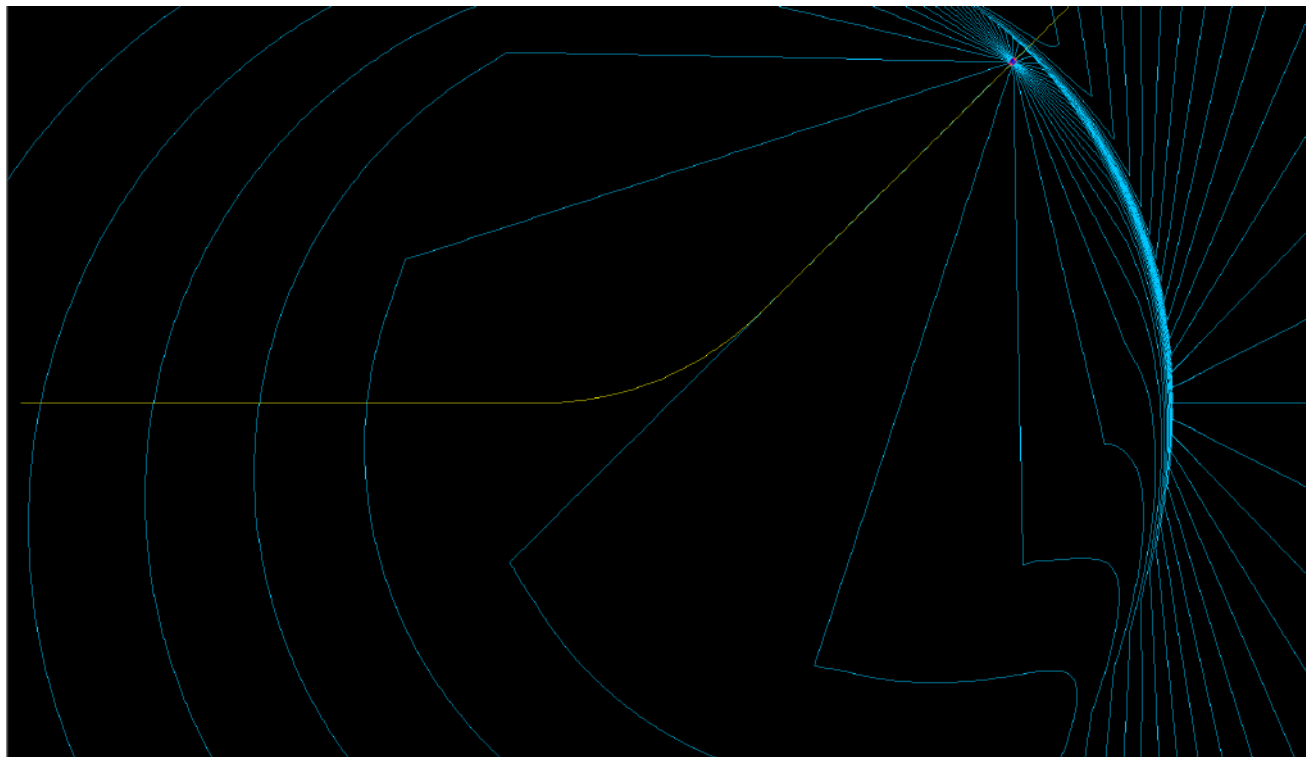

# RADIAZIONE DA PARTICELLE CARICHE ULTRARELATIVISTICHE: DIPOLO

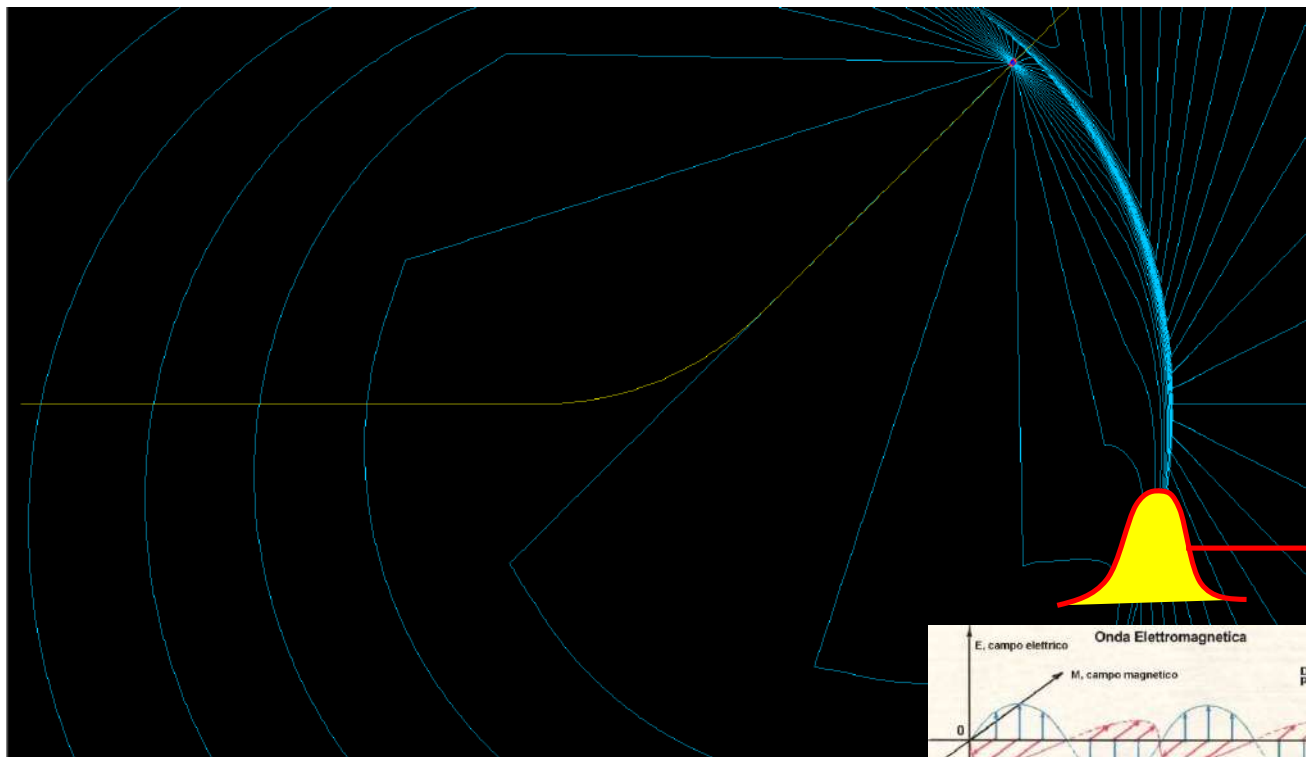

Onda piana

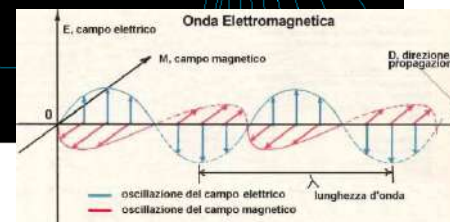

# RADIAZIONE DA PARTICELLE CARICHE ULTRARELATIVISTICHE: ONDULATORE

Carica in movimento

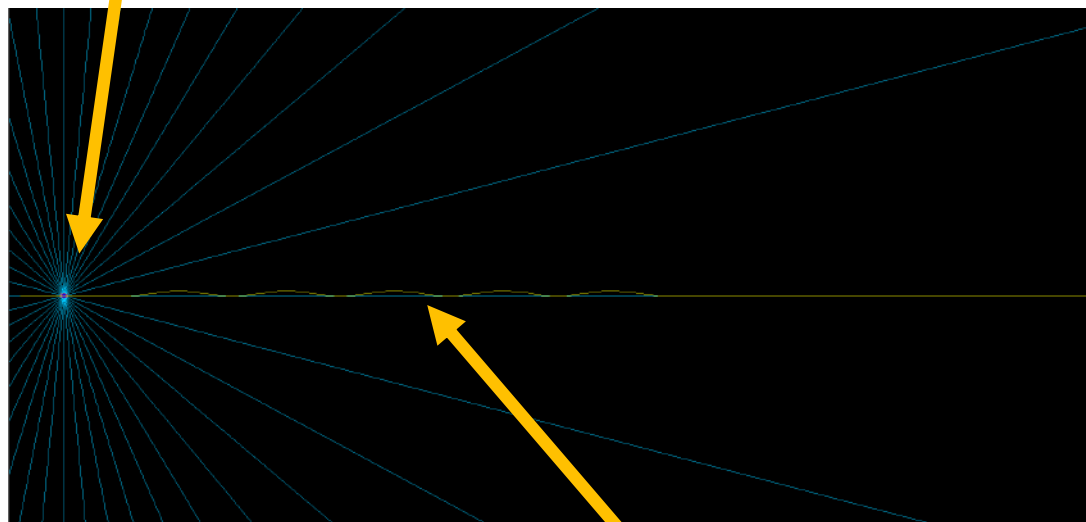
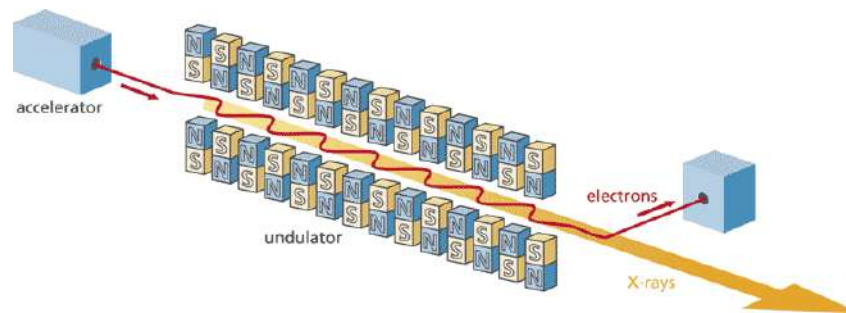

Traiettoria in un  
ondulatore

# RADIAZIONE DA PARTICELLE CARICHE ULTRARELATIVISTICHE: ONDULATORE

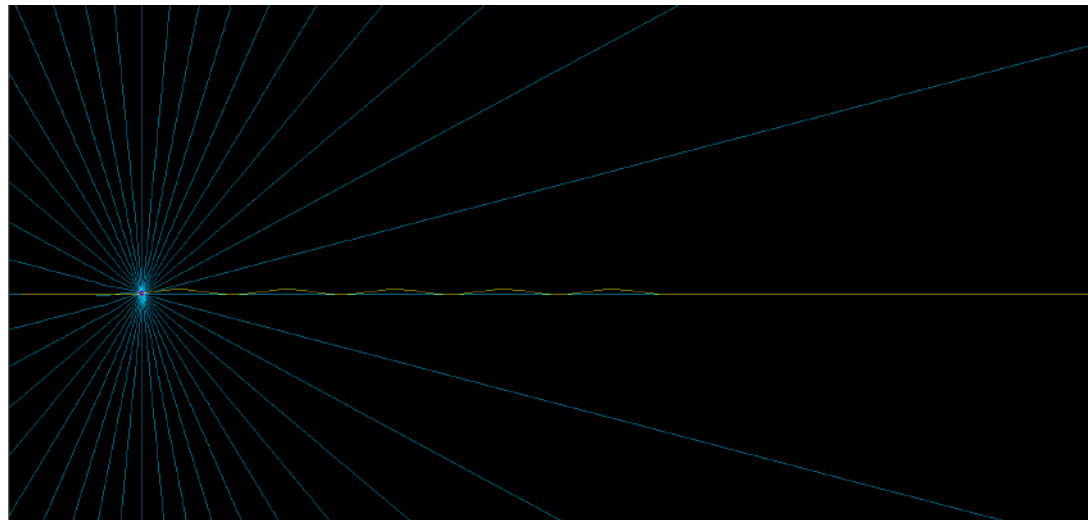

# RADIAZIONE DA PARTICELLE CARICHE ULTRARELATIVISTICHE: ONDULATORE

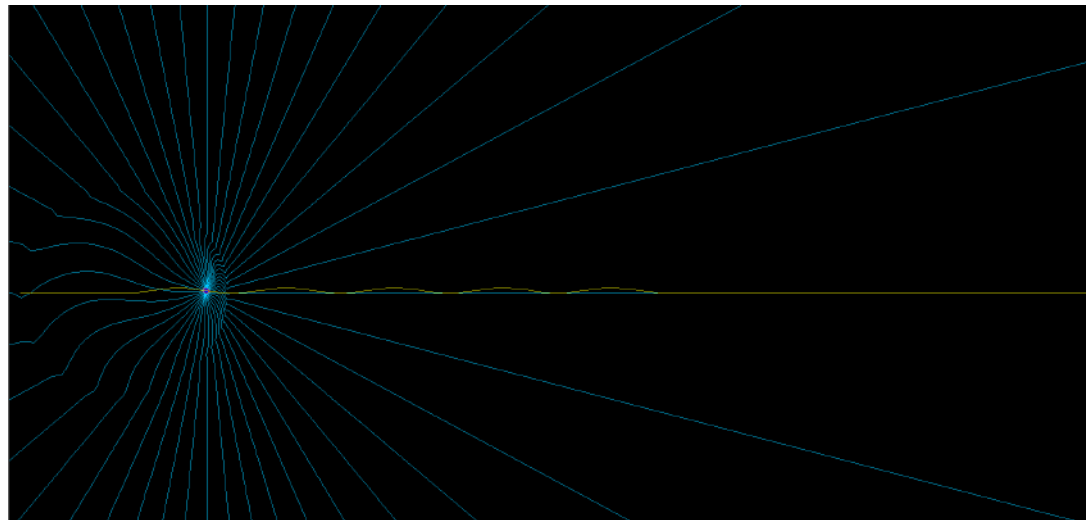

# RADIAZIONE DA PARTICELLE CARICHE ULTRARELATIVISTICHE: ONDULATORE

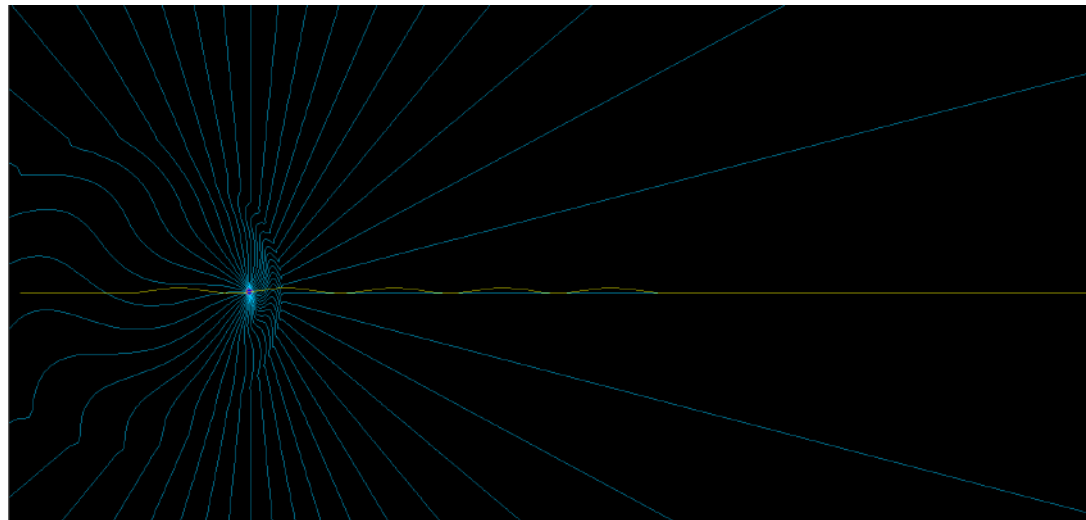

# RADIAZIONE DA PARTICELLE CARICHE ULTRARELATIVISTICHE: ONDULATORE

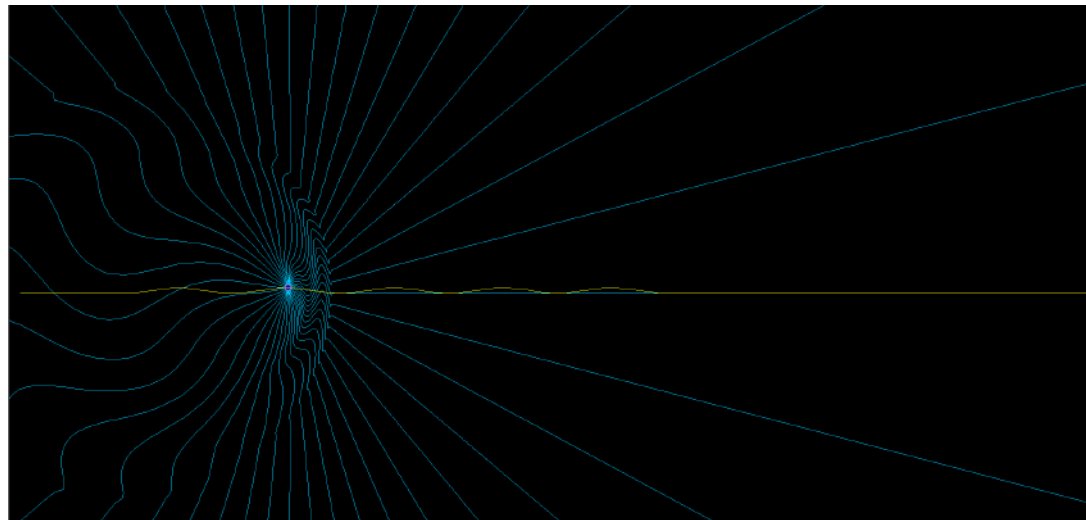

# RADIAZIONE DA PARTICELLE CARICHE ULTRARELATIVISTICHE: ONDULATORE

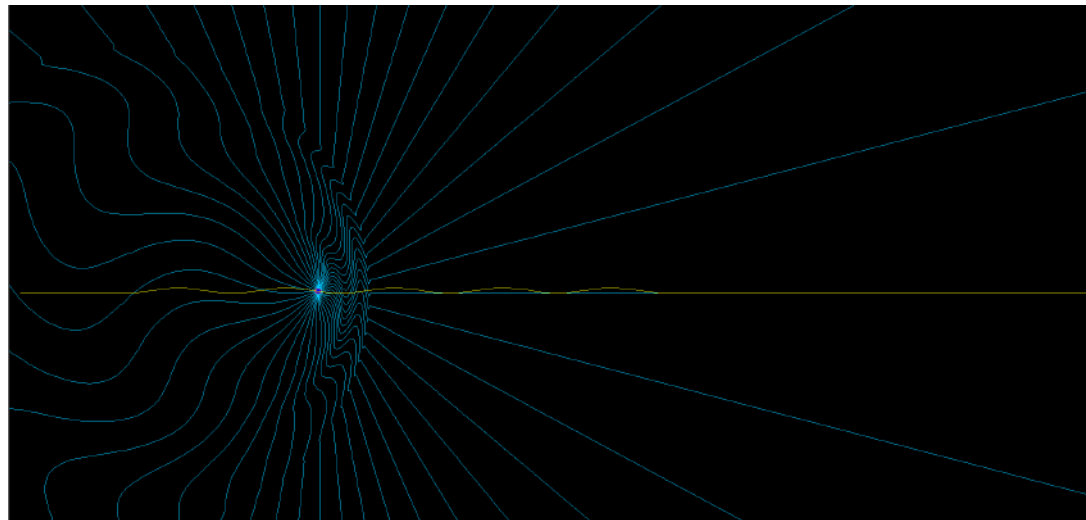

# RADIAZIONE DA PARTICELLE CARICHE ULTRARELATIVISTICHE: ONDULATORE

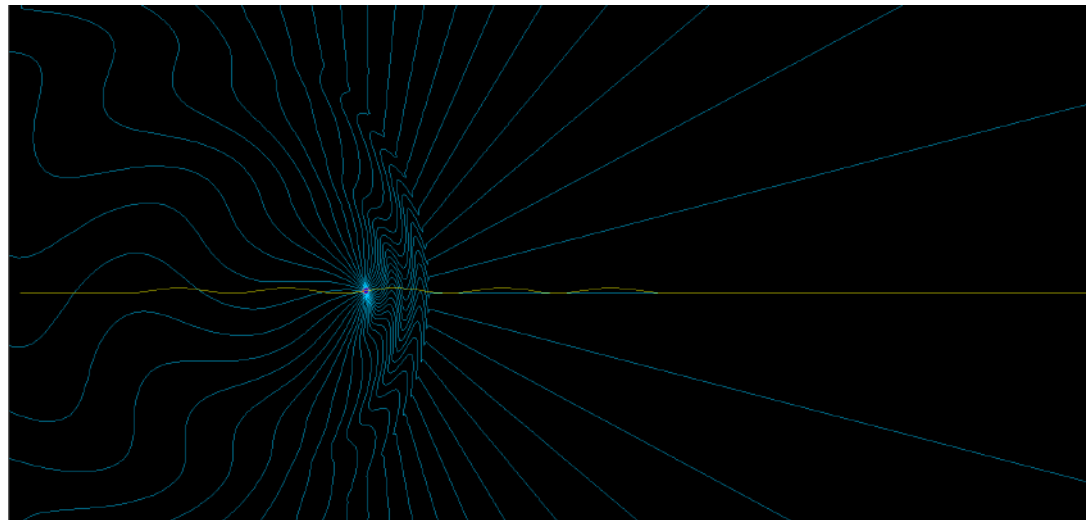

# RADIAZIONE DA PARTICELLE CARICHE ULTRARELATIVISTICHE: ONDULATORE

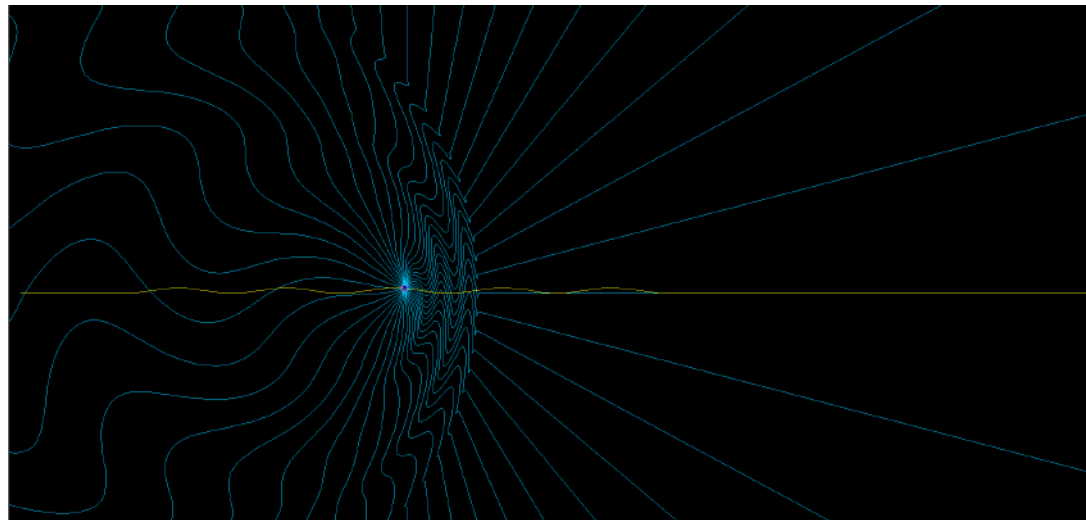

# RADIAZIONE DA PARTICELLE CARICHE ULTRARELATIVISTICHE: ONDULATORE

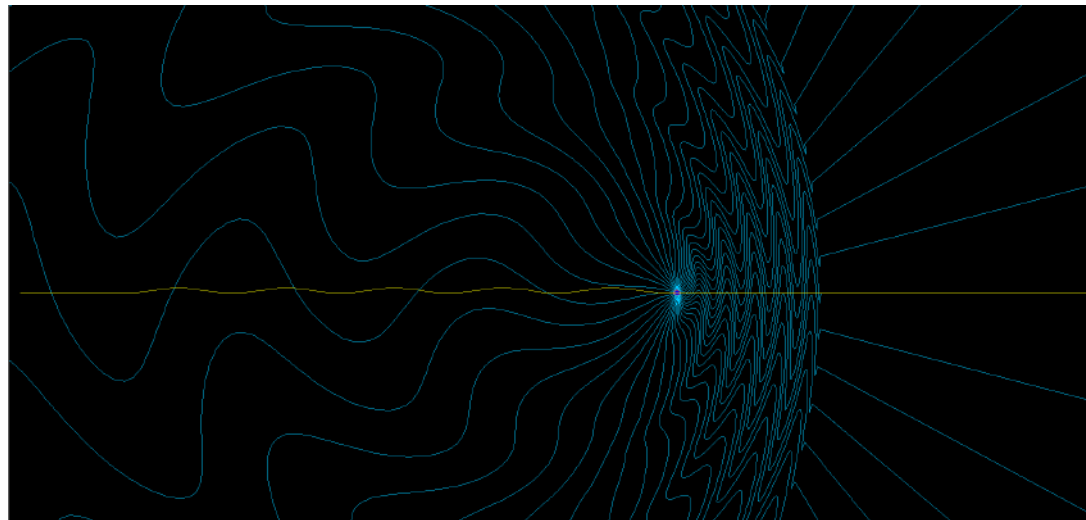

# RADIAZIONE DA PARTICELLE CARICHE ULTRARELATIVISTICHE: ONDULATORE

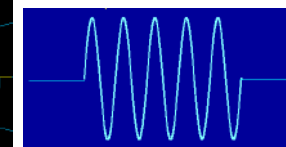
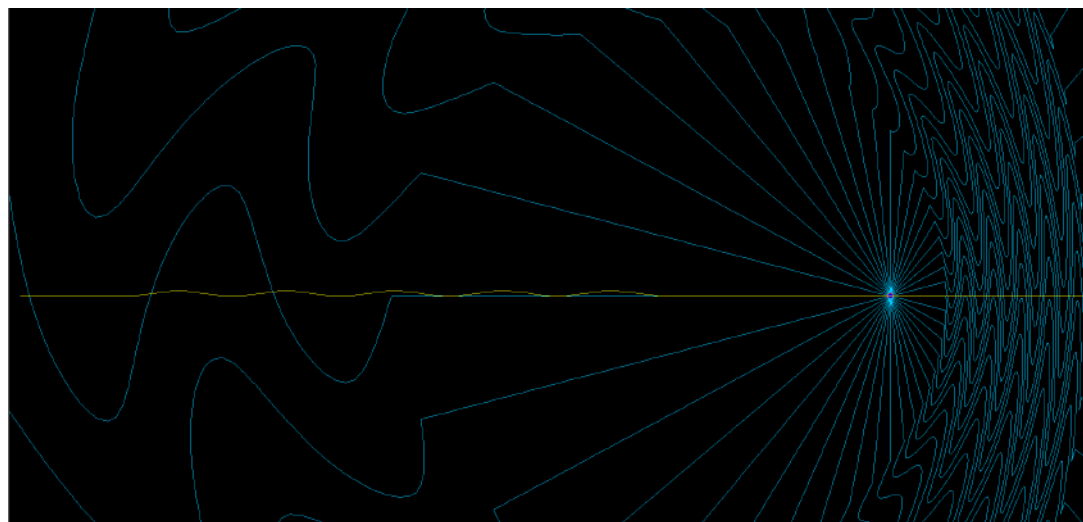
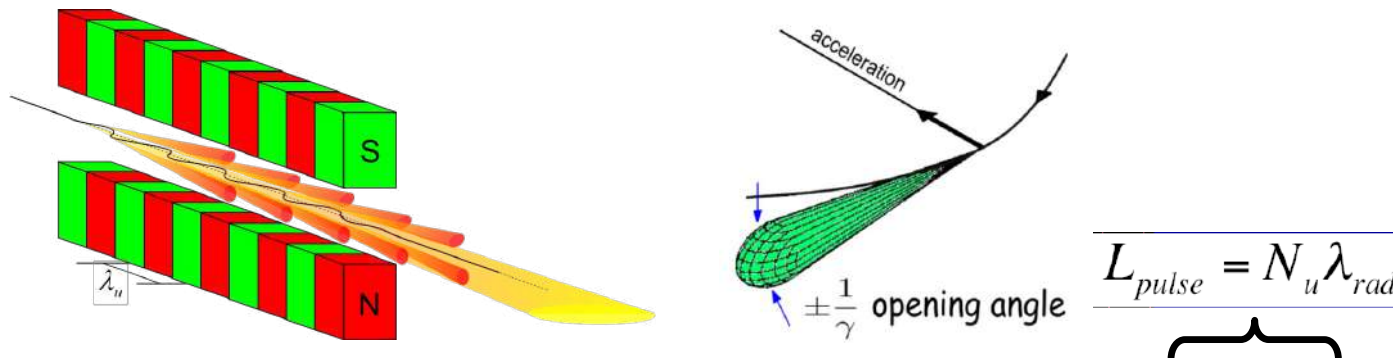

# PROPRIETA' DELLA RADIAZIONE DI SINCROTRONE

La radiazione di sincrotrone viene emessa in un *ampio spettro*. La lunghezza d'onda critica identifica il *picco dello spettro* ed è funzione dell'energia degli elettroni ( $\gamma^3$ ).

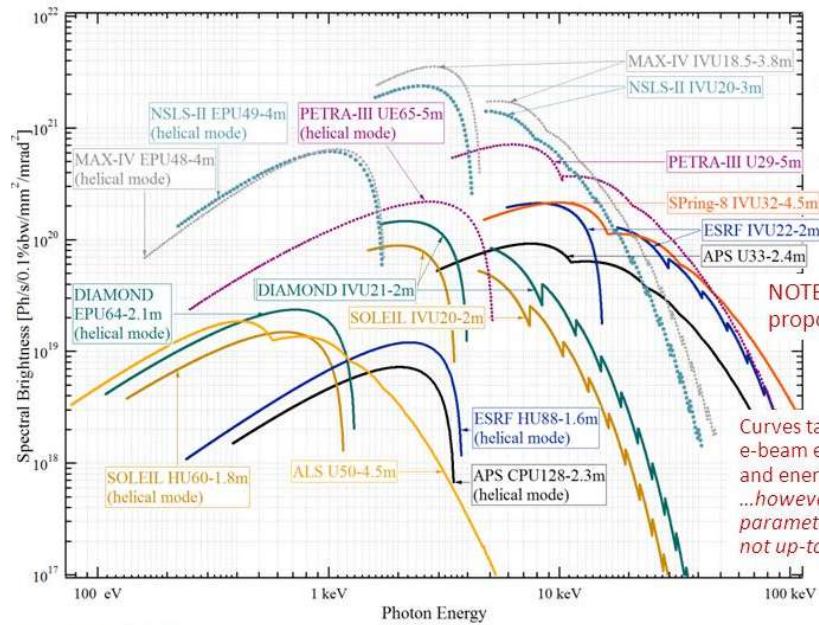
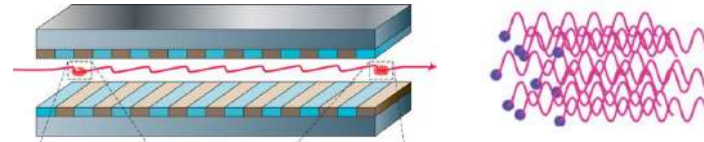

$$\omega_c = \frac{3}{2} \frac{c}{\rho} \gamma^3$$

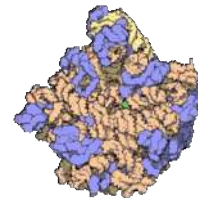
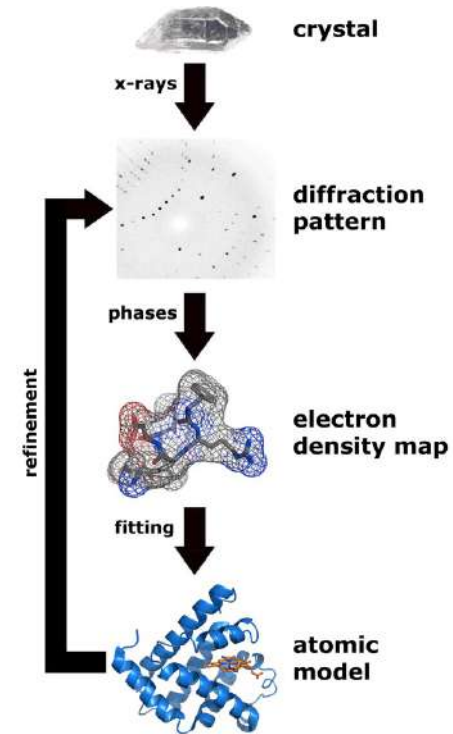

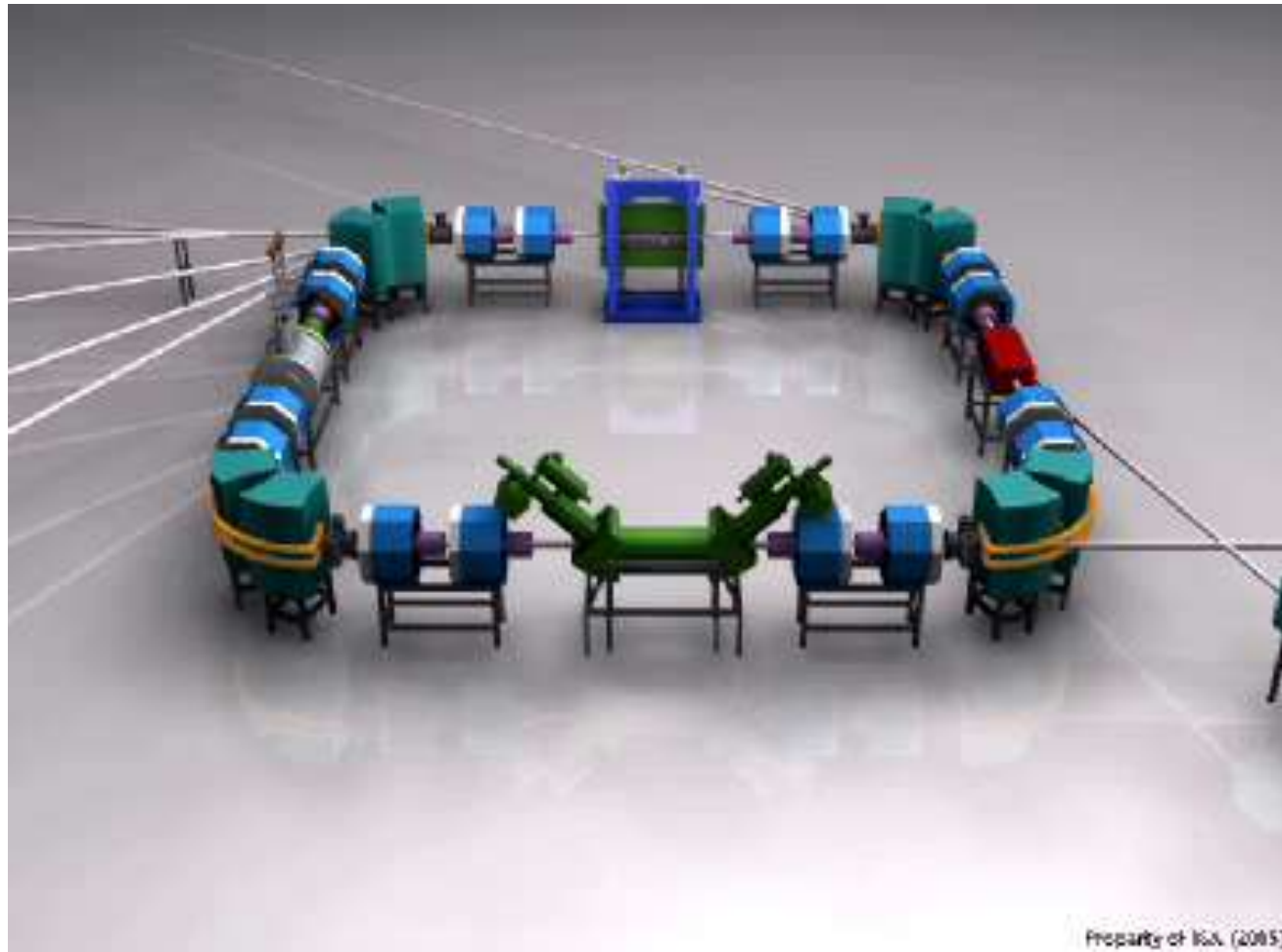

<http://www.isa.au.dk/animations/animations.asp>

# SINCROTRONI DEDICATI ALLA “PRODUZIONE” DI LUCE



# BRIGHTNESS OF A PHOTON SOURCE

The most important parameter for a light source is not (only) the number of emitted photons per second but their “density” called **brightness**.

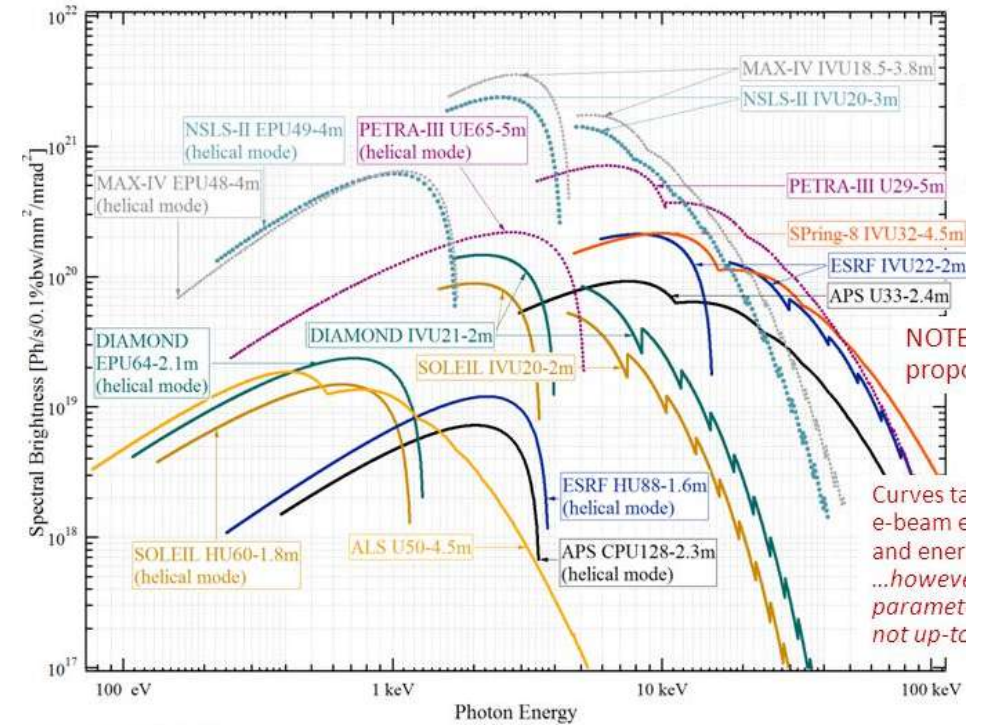
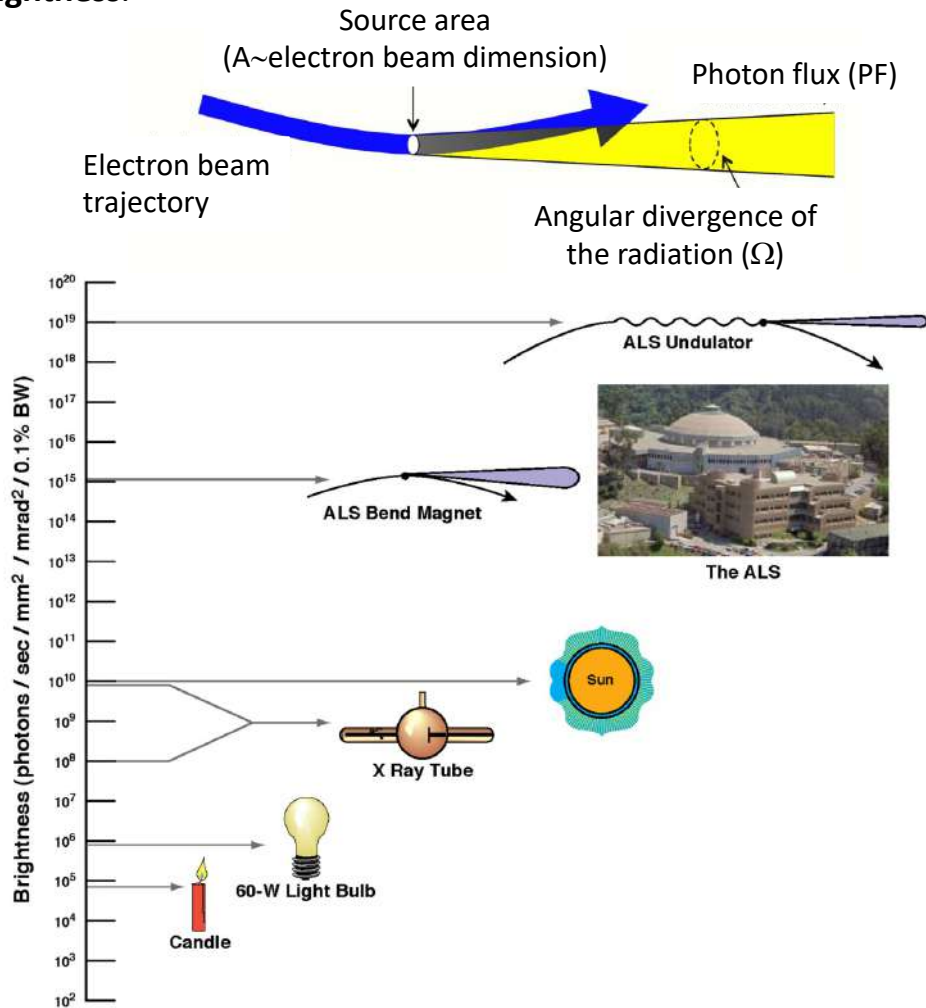

$$\text{Brightness} = \frac{PF [ph/s]}{A [mm^2] \times \Omega [mrad^2]}$$

# Laser ad elettroni liberi: *Free Electron Lasers (FEL)*

I Laser ad Elettroni Liberi sono **potenti sorgenti di radiazione elettromagnetica coerente** (microonde, UV, raggi X) con **alta potenza di picco e alta brillantezza** (ordini di grandezza superiori agli anelli di luce di sincrotrone).

Un **LINAC ad e-** accelera **pacchetti** di elettroni di alta qualità (brillantezza) che, entrando nell'ondulatore, generano radiazione EM coerente, con un'amplificazione esponenziale.

All'interno degli ondulatori si ha in particolare una interazione luce emessa-elettroni del pacchetto che porta ad un fenomeno di **auto-impacchettamento (micro-bunching)** del pacchetto di elettroni su scala della lunghezza d'onda della radiazione emessa. I vari elettroni impacchettati emettono così coerentemente.

Tale **tipo di radiazione ha enormi applicazioni** poiché consente analisi di strutture anche non cristallizzate.

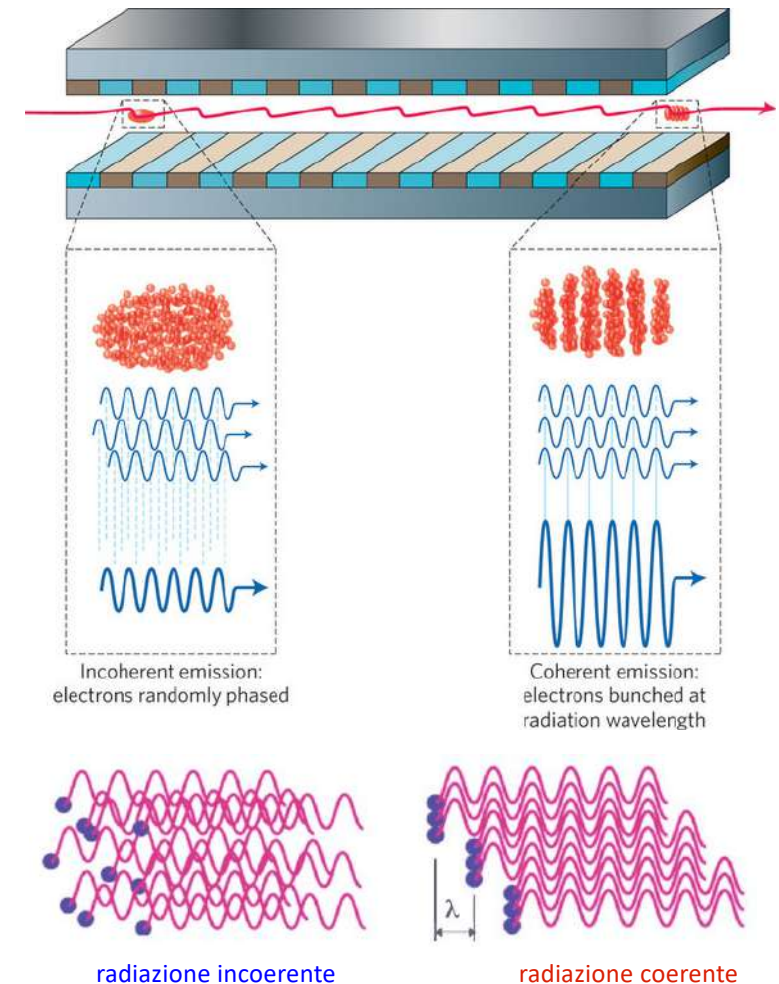

# FEL: RADIAZIONE COERENTE ED IMPULSI ULTRA-CORTI

⇒ la **radiazione coerente** emessa da un FEL consente di «fotografare» anche molecole o sistemi non cristallizzati

⇒ con i FEL è possibile generare **impulsi ultra-corti** (fs) con cui è possibile «filmare» movimenti di molecole, passaggi di carica etc...

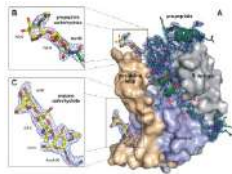

Inhibited Trypanosoma brucei Cathepsin B Structure Determined by Using an Xray Laser, L. Redecke et al. Science 339, 227 (2013)

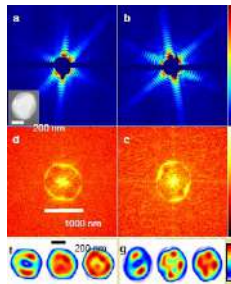

Imaging single mimivirus Seibert et al, Nature, 470, 78 (2011)

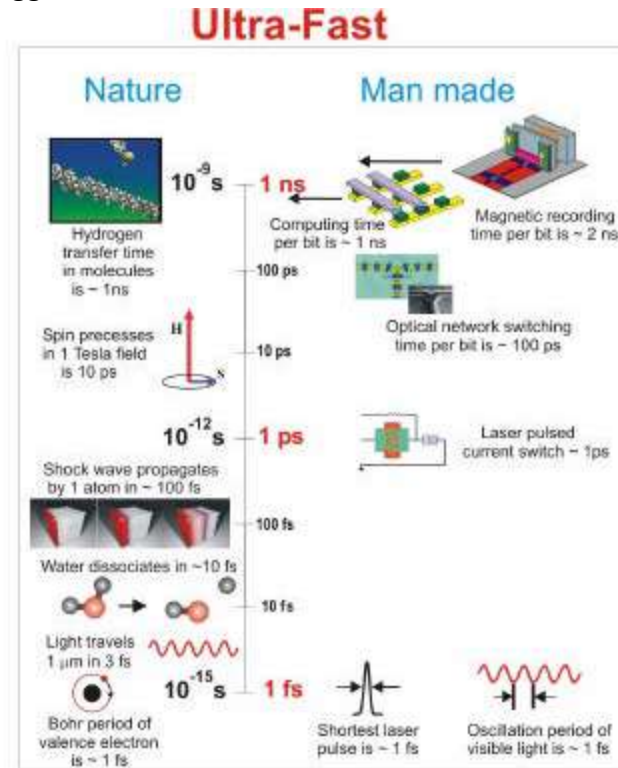
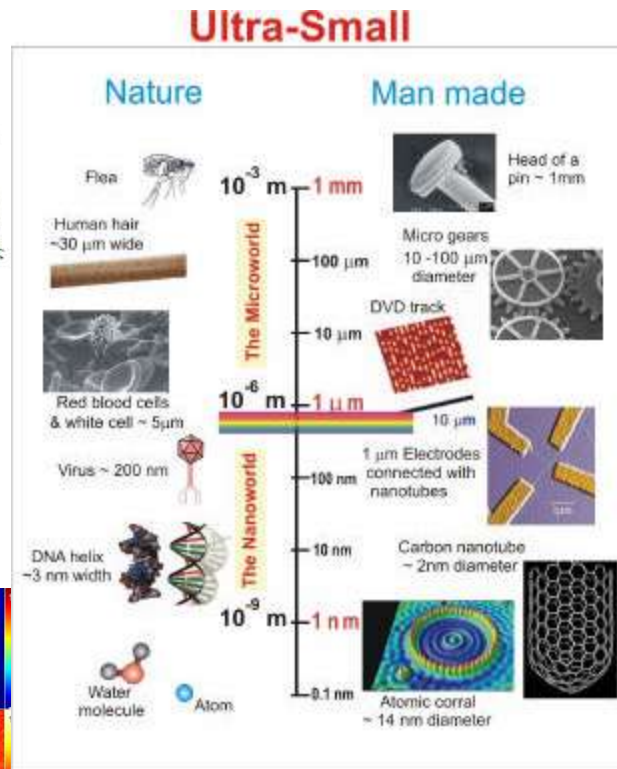

Simulated X-ray Raman Redistribu'on: (example: Metalloporphyrn)

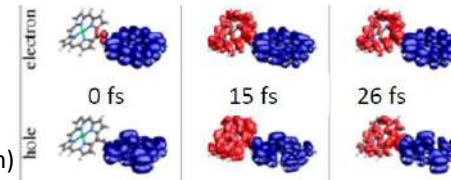

Courtesy C. Pellegrini and J. Stohr

# SORGENTI DI RAGGI X E $\gamma$ BASATE SU COLLISIONI ELETTRONI-FOTONI

Sorgente di  
elettroni



LINAC (100-800 MeV)

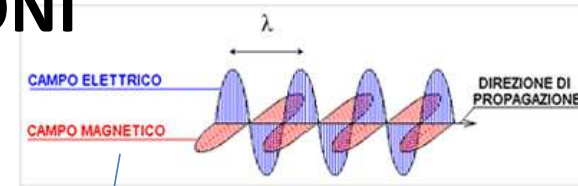

LASER

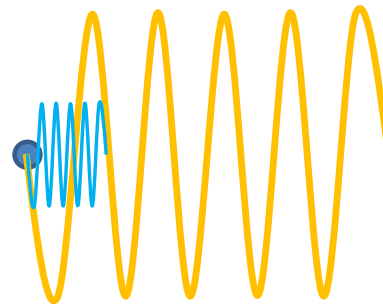

Il fascio di fotoni emesso  
può coprire uno spettro di  
radiazione dai raggi X ai  
raggi  $\gamma$



I fasci di raggi  $\gamma$  hanno  
una lunghezza d'onda  
così piccola che **da  
poter interagire con i  
nuclei degli atomi**  
fornendo informazioni  
sulla struttura nucleare  
dell'atomo stesso

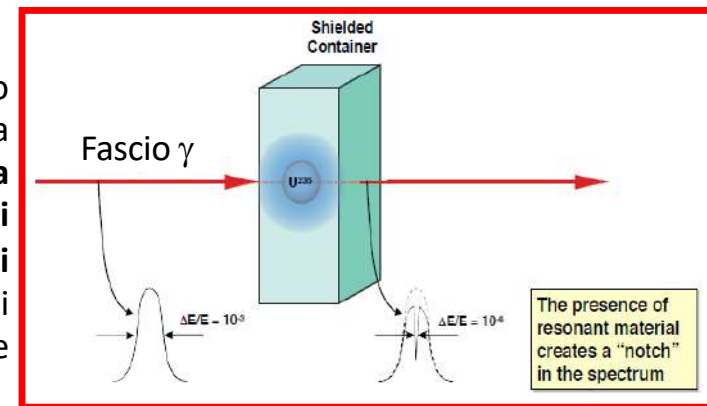

# ACCELERATORI PER SORGENTI DI NEUTRONI

**The Nobel Prize in Physics 1994**

**Neutrons reveal structure and dynamics**

Neutrons reveal the structure and dynamics of matter. They are used to study the structure of materials, the dynamics of molecules, and the structure of the Earth's interior.

Neutrons show where atoms are. Neutrons show what atoms do.

Neutrons are used to study the structure of materials, the dynamics of molecules, and the structure of the Earth's interior.

Neutrons are used to study the structure of materials, the dynamics of molecules, and the structure of the Earth's interior.

Neutrons are used to study the structure of materials, the dynamics of molecules, and the structure of the Earth's interior.

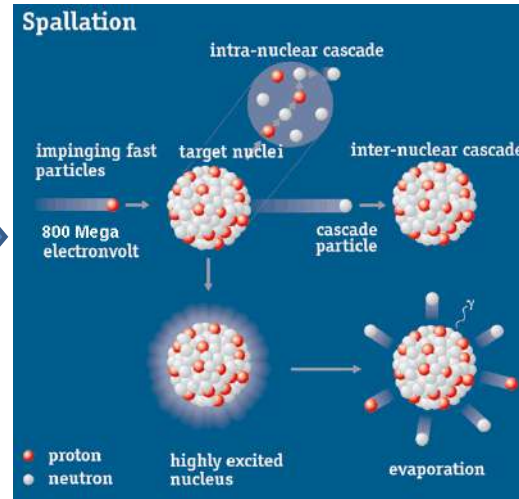

spallazione

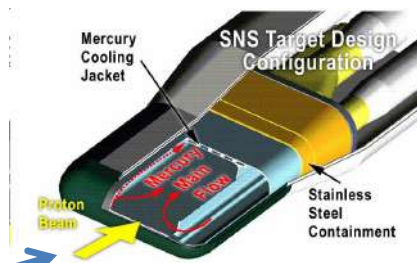
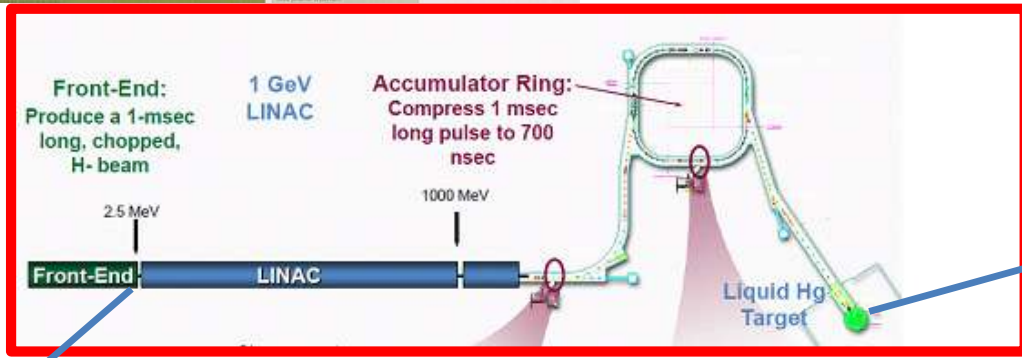

$10^{15} \text{ n/s/cm}^2$



# FISICA FONDAMENTALE: COLLISORI (COLLIDERS)

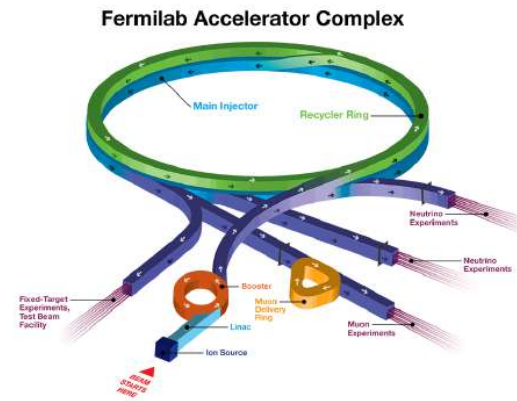
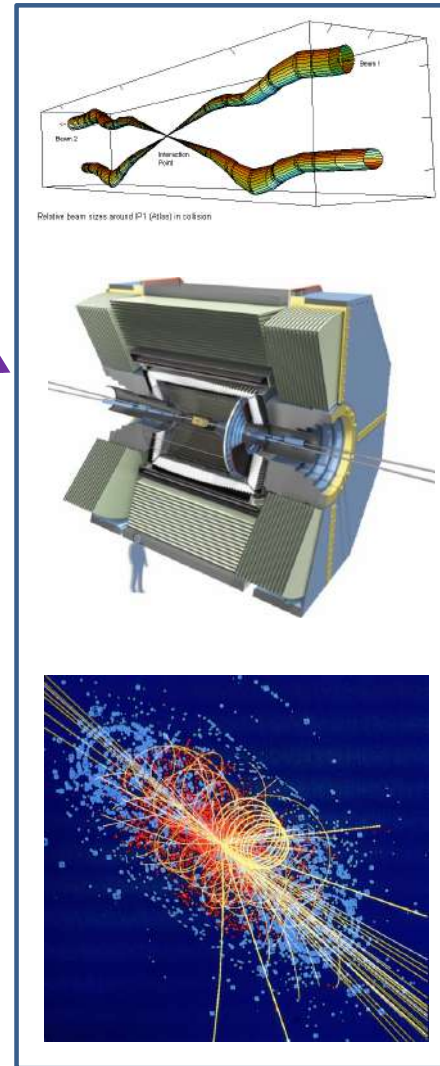
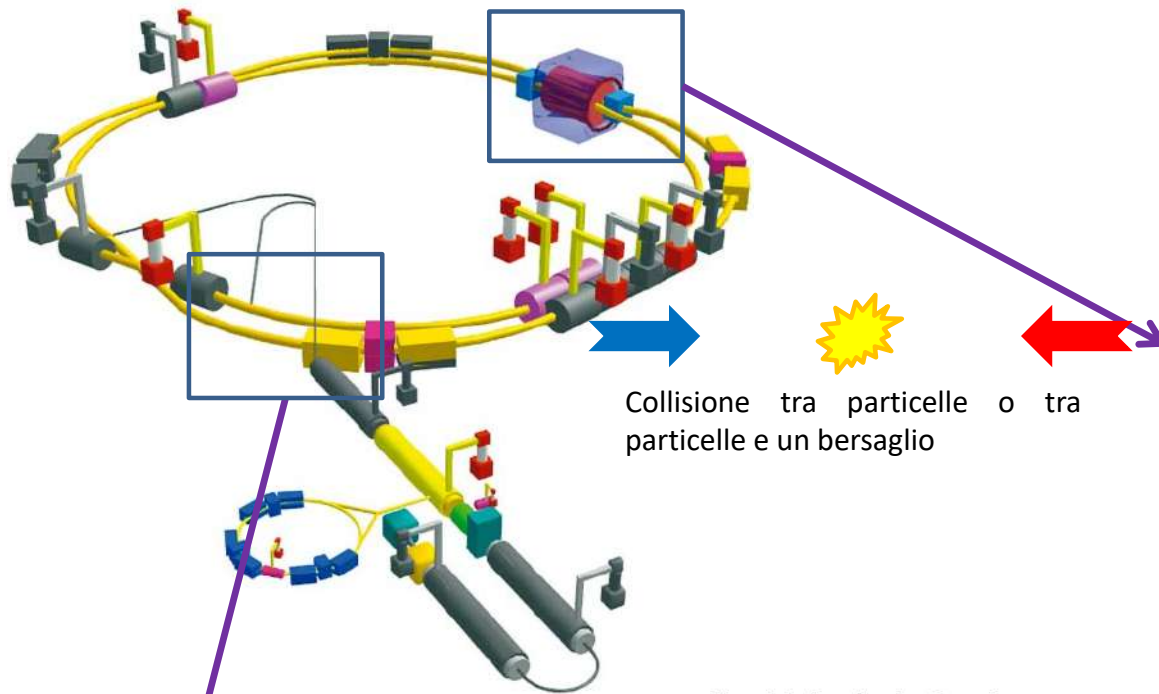

# ACCELERATORI DI PARTICELLE: MICROSCOPI SUB-ATOMICI E MACCHINE DEL TEMPO

Le collisione tra due fasci di particelle o tra un fascio di particelle e un bersaglio ...

Forniscono informazioni sui costituenti ultimi del nostro universo e sulle leggi che li governano (**microscopio**)

Ricreando **densità di energia** sempre più elevate, consente di risalire ai primi istanti di vita dell'Universo e di studiarne l'evoluzione (**macchina del tempo**)

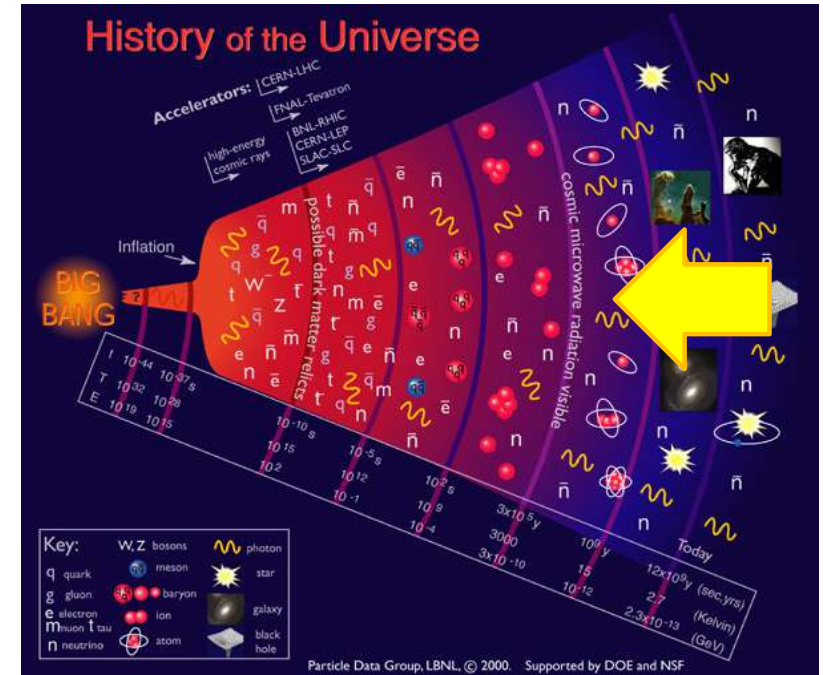
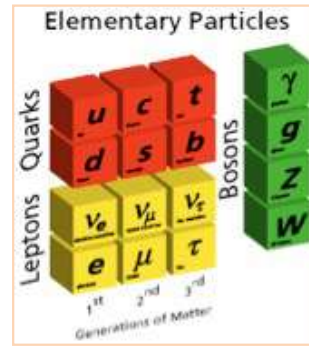
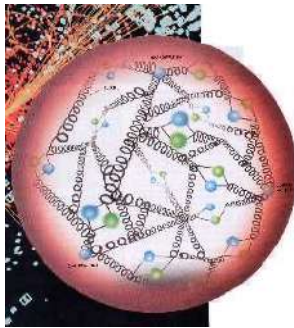

# COLLISIONI: ENERGIA O DENSITA' DI ENERGIA?

L' eV rappresenta un'energia molto piccola

$$1 \text{ eV} = 1\text{V} \times 1.6 \cdot 10^{-19} \text{ C} = 1.6 \times 10^{-19} \text{ J}$$

$$1 \text{ MeV} = 1.6 \times 10^{-13} \text{ J}$$

$$1 \text{ GeV} = 1.6 \times 10^{-10} \text{ J}$$

Un proiettile di piombo da 200 g lanciato a 300 m/s ha un'energia di 9000 J



Ma ogni singolo protone o neutrone del proiettile ha una energia cinetica piccolissima  $9000/N_{p+n} \cong 7 \cdot 10^{-23} \text{ J} \cong 0.0005 \text{ eV}$ !



In un *acceleratore come LHC* si raggiungono energie per ogni protone di 7 TeV ( $7 \times 10^{12}$  eV)!

**La densità di energia disponibile per le reazioni nucleari o sub-nucleari è enorme!**



# Sviluppo degli acceleratori di particelle

La capacità di “creare” nuove particelle e di “rompere” i legami nucleari *augmenta con l'energia* e con la quantità di particelle coinvolte nell' interazione.

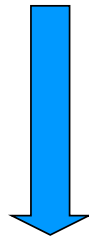

Lo sviluppo degli acceleratori per la fisica delle alte energie è stato determinato dalla necessità di ottenere energie e intensità di fasci sempre maggiori.

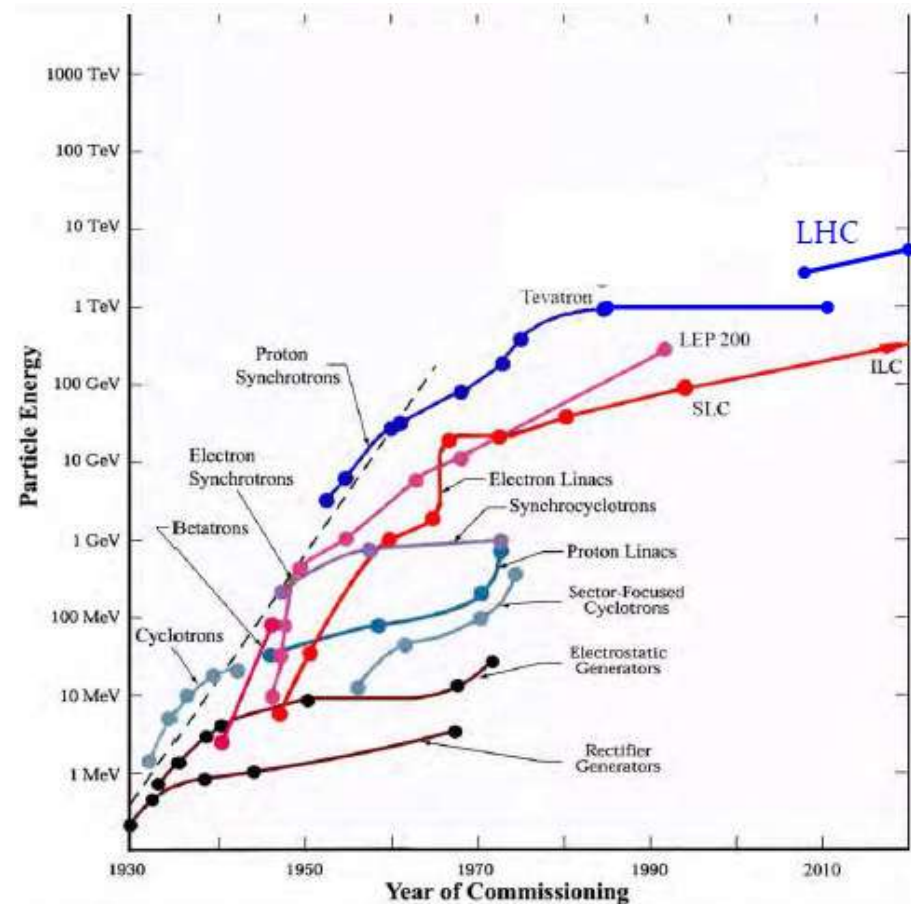

Courtesy M. Biagini

L'unità di misura dell'energia delle particelle è l'elettronvolt [eV]  $1 \text{ eV} = 1.6 \times 10^{-19} \text{ J}$

## Fisica delle Particelle con Acceleratori: collisioni su targhetta fissa

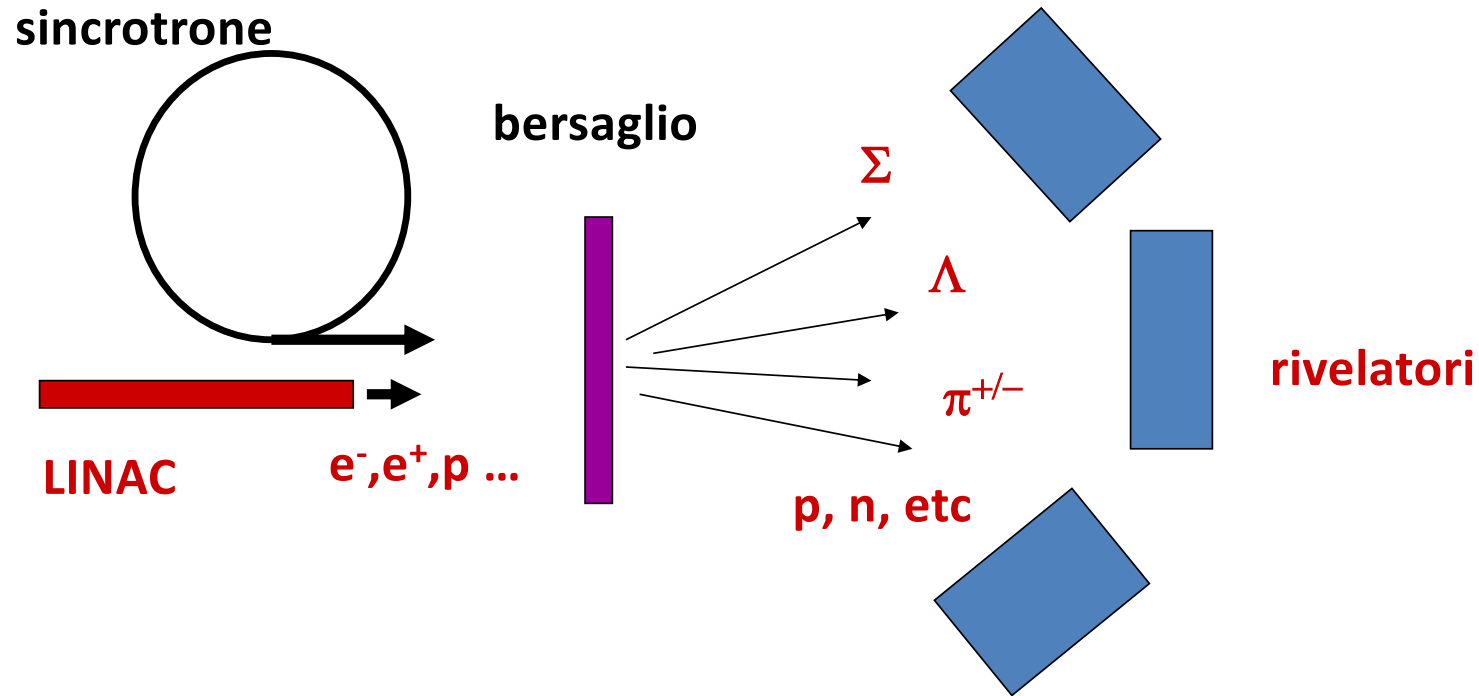

- 1) La materia è **vuota** : ciò che non ha interagito viene perduto;
- 2) Il bersaglio è **complesso**: molte delle particelle prodotte disturbano l'esperimento;
- 3) Rivelatore "**anisotropo**";
- 4) Parte dell'energia del fascio di particelle **non viene "sfruttata"** nell'interazione in quanto posseduta dal Centro di Massa del sistema in movimento;

# Nascita dei Moderni Collider (Collisori)



La geniale idea di **Bruno Touschek** (1960) fu quella di utilizzare come particelle collidenti, *particelle ed antiparticelle* che, nella loro annichilazione, avrebbero rilasciato *tutta la loro energia* per creare nuove particelle. Inoltre i *prodotti delle collisioni sarebbero stati relativamente "semplici"* rispetto a quelli prodotti dalla collisione contro un bersaglio complesso.

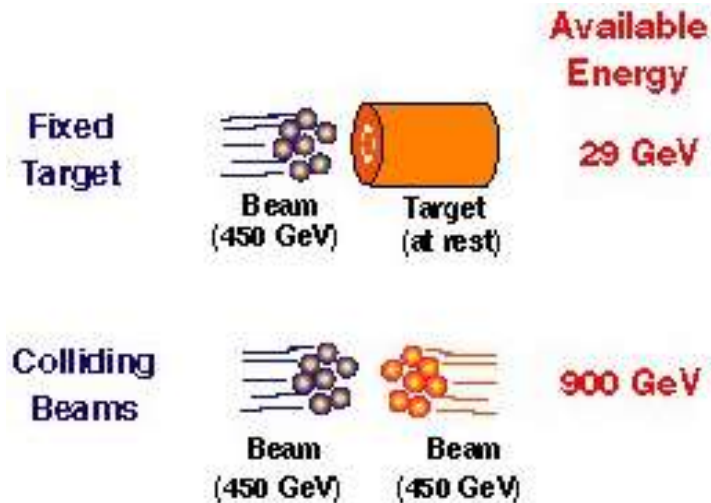
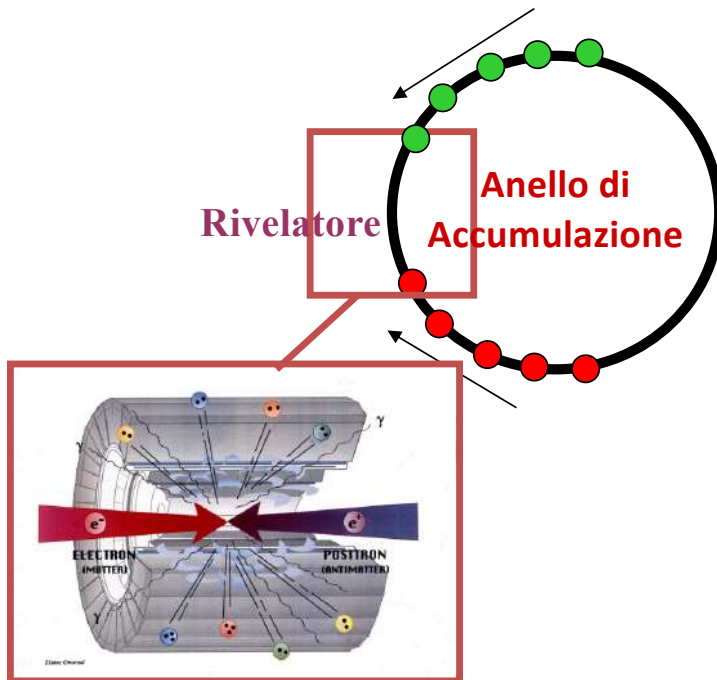

# AdA (Anello di Accumulazione) 1960-1965

AdA è costituito da un magnete a foceggiamento debole in grado di far circolare particelle ( $e^+/e^-$ ) con una energia di **250 MeV**.

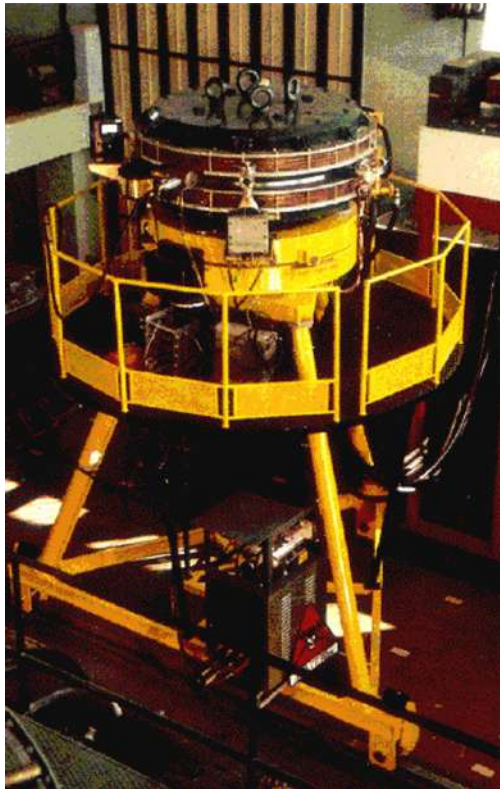

Length of orbit . . . . .	408	cm
Radio frequency ( $k=2$ )	147	MHz
Radio voltage . . . . .	10	kV
Length of bunches . . . . .	16.7	cm
Radial width of bunches	.22	cm
Height of bunches (at $10^{-10}$ mm) . . . . .	$5.6 \cdot 10^{-4}$	cm
Radiation loss/revolution	580	eV
Lifetime of beam at $10^{-10}$ mm . . . . .	250	h

## IL NUOVO CIMENTO

### The Frascati Storage Ring.

C. BERNARDINI, G. P. CORAZZA, G. GHIGO  
*Laboratori Nazionali del CNEN - Frascati*

R. TOSCHER  
*Istituto di Fisica dell'Università - Roma  
 Istituto Nazionale di Fisica Nucleare - Sezione di Roma*

(ricevuto il 7 Novembre 1960)

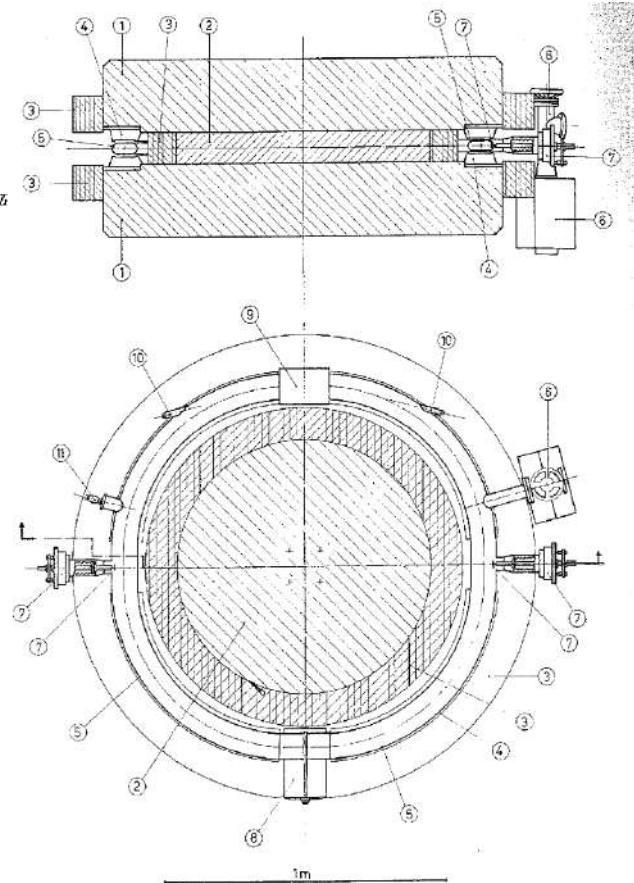
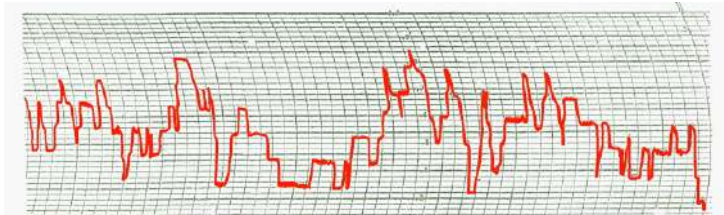

Fig. 1. - Elevation and plan section of the Frascati Storage Ring (anello di accumulazione - AdA): 1) magnet pole; 2) magnet core; 3) coils; 4) polepieces; 5) doughnut; 6) transverse pump; 7) injection ports; 8) RF cavity; 9) experimental section; 10) windows for the observation of the synchrotron radiation; 11) vacuum gauge.



Registrazione dei primi elettroni accumulati in AdA. La vita media era 21 sec, il numero medio 2.3.

## ADONE ( 1967-1993 )

Dal successo di AdA si decise di costruire un anello di accumulazione dello stesso tipo ad una energia più elevata (**1.5 GeV per fascio**, 105 m): **ADONE**



La **costruzione della nuova macchina iniziò nel 1963** e il primo elettrone fu immagazzinato nel 1967. Un LINAC di 350 MeV fu utilizzato come iniettore. La corrente massima circolante in ADONE era di **100 mA in 3 pacchetti**.

Si raggiunse la luminosità di progetto:  $3 \times 10^{29} \text{ cm}^{-2} \text{ s}^{-1}$ .

ADONE fu spento il 26 Aprile 1993.

# La $\Phi$ -Factory a Frascati

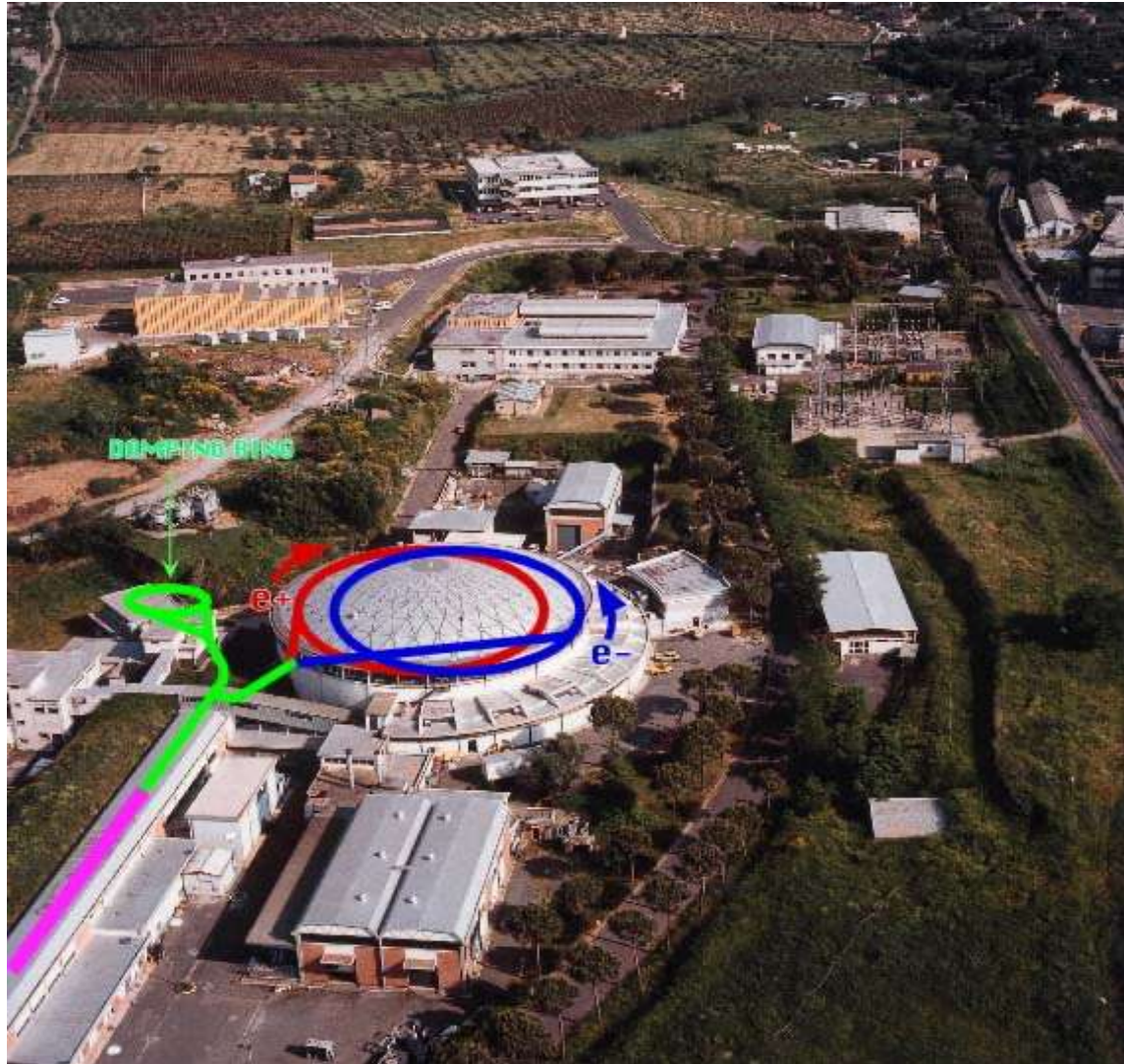

# Sezione d'urto e luminosità di un collider

Due particelle ( $e^+/e^-$  a DAΦNE ,ad esempio) che collidono possono produrre **tipi diversi di eventi**, alcuni più probabili di altri. La **sezione d'urto** di un determinato evento è **proporzionale alla probabilità che l'evento avvenga** e si misura in  $\text{cm}^2$ .

Relativamente ad un determinato evento **tutto va come se** le particelle avessero un'"area" finita (misurata in  $\text{cm}^2$ ). L'interazione avviene se le due particelle si "toccano".



**Evento poco probabile.**  
A bassa sezione d'urto

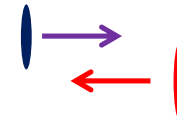

**Evento più probabile.**  
Ad elevata sezione d'urto

Le **sezioni d'urto sono tipicamente molto piccole** infatti l'unità di misura dell'area, per misurare sezioni d'urto tra particelle elementari, è il **barn**.

Dimensionalmente il barn è un'area, ed è pari a:  $10^{-28} \text{ m}^2$  ovvero  $10^{-24} \text{ cm}^2$

In un collider la frequenza con cui accadono gli eventi cercati si può esprimere come il prodotto  $L\sigma$  ove L è detta **luminosità del Collider**.



La luminosità del collider è genericamente definita come l'integrale di sovrapposizione (overlap) tra i due fasci di particelle nelle 4-dimensioni ( $x,y,z,t$ ). Essa ci fornisce una misura di quante interazioni fascio-fascio stiamo producendo

$$\mathcal{L} = \int_c \int \int \int_{-\infty}^{+\infty} e^+(x, y, s + ct) e^-(x, y, s - ct) 2cdt ds dx dy$$

# LUMINOSITY

The luminosity is related to:

- the amount of colliding particles
- frequency of collision
- the beams dimensions at the interaction point

For gaussian beams



Number of particles per beam ( $\sim 10^{10}$ )

Collision frequency (up to hundreds of MHz)

$$L = \frac{N^{e^+} N^{e^-}}{4\pi\sigma_x \sigma_y} \times f_{collision} \quad [cm^{-2} sec^{-1}]$$

Transverse dimensions at the Interaction point (IP): up to few  $\mu$  (or even less)

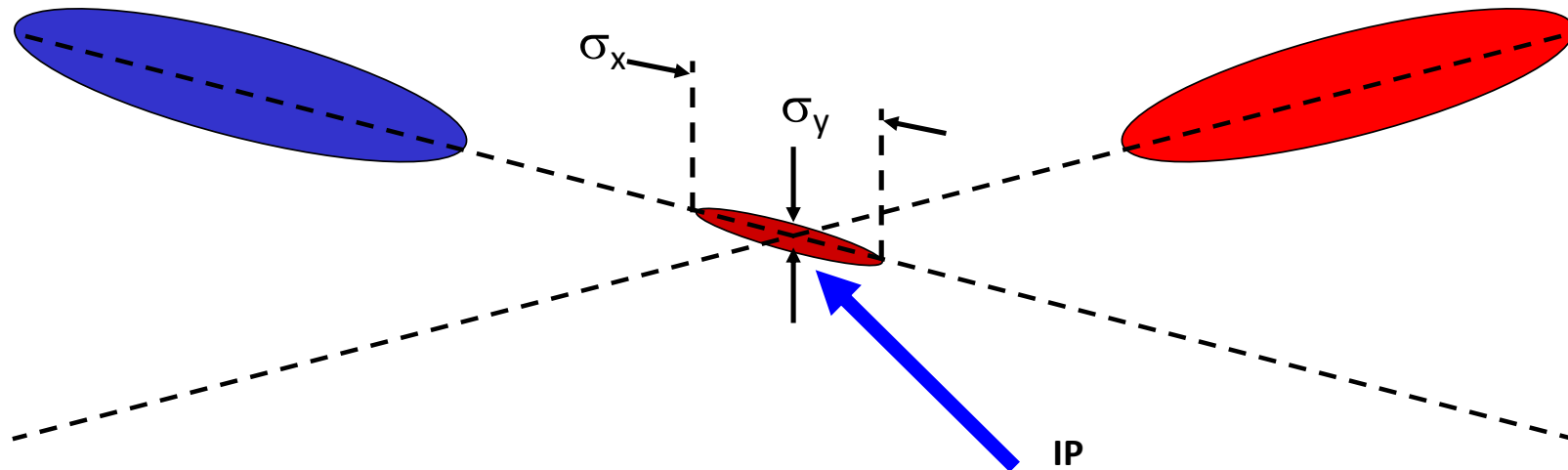

# Luminosità di un *collider*

Numero di particelle per fascio

$$L = \frac{N^{e^+} N^{e^-}}{4\pi\sigma_x \sigma_y} \times f_{\text{collisione}} \quad [\text{cm}^{-2} \text{sec}^{-1}]$$

Dimensioni trasverse dei fasci nell'IP:  
Si può arrivare a pochi millesimi di mm

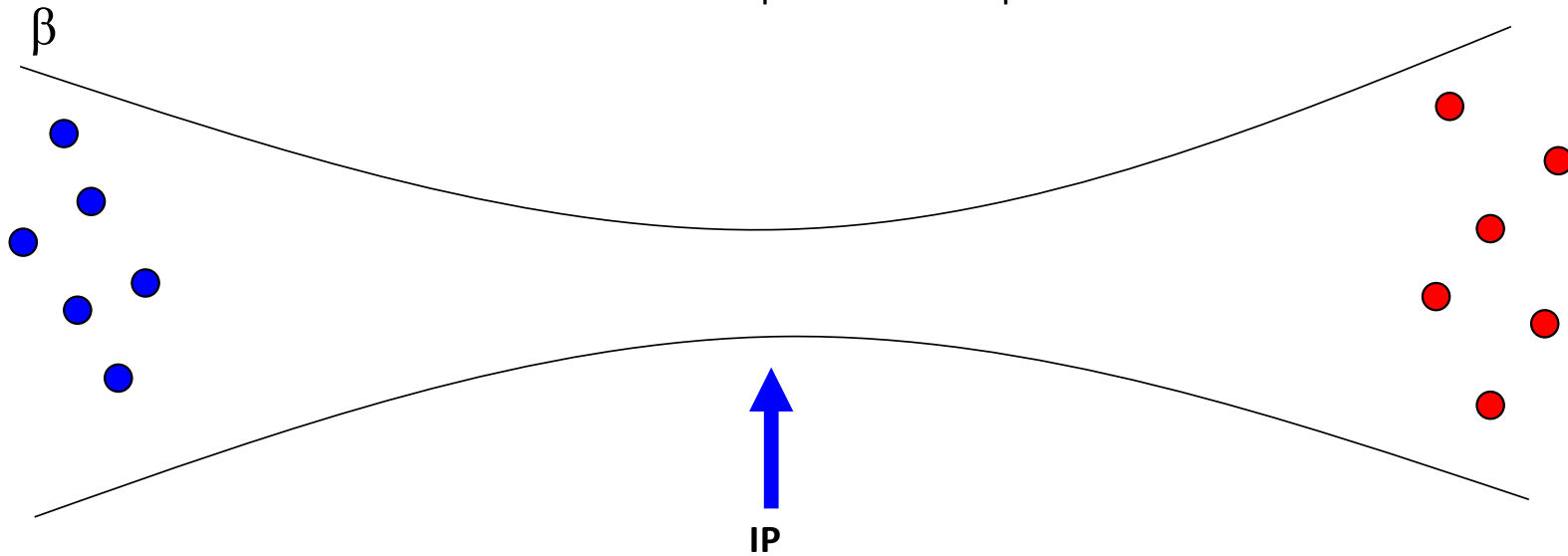

# Luminosità di un *collider*

Numero di particelle per fascio

$$L = \frac{N^{e^+} N^{e^-}}{4\pi\sigma_x \sigma_y} \times f_{\text{collisione}} \quad [\text{cm}^{-2} \text{sec}^{-1}]$$

Dimensioni trasverse dei fasci nell'IP:  
Si può arrivare a pochi millesimi di mm

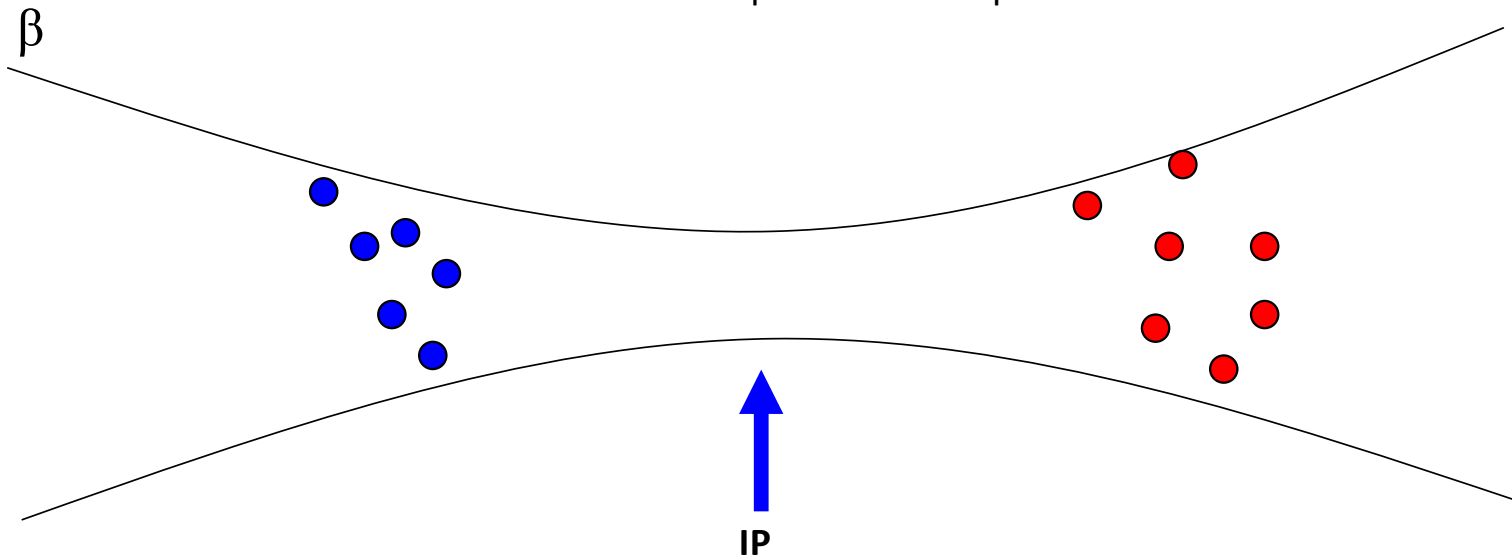

# Luminosità di un *collider*

Numero di particelle per fascio

$$L = \frac{N^{e^+} N^{e^-}}{4\pi\sigma_x \sigma_y} \times f_{\text{collisione}} \quad [\text{cm}^{-2} \text{sec}^{-1}]$$

Dimensioni trasverse dei fasci nell'IP:  
Si può arrivare a pochi millesimi di mm

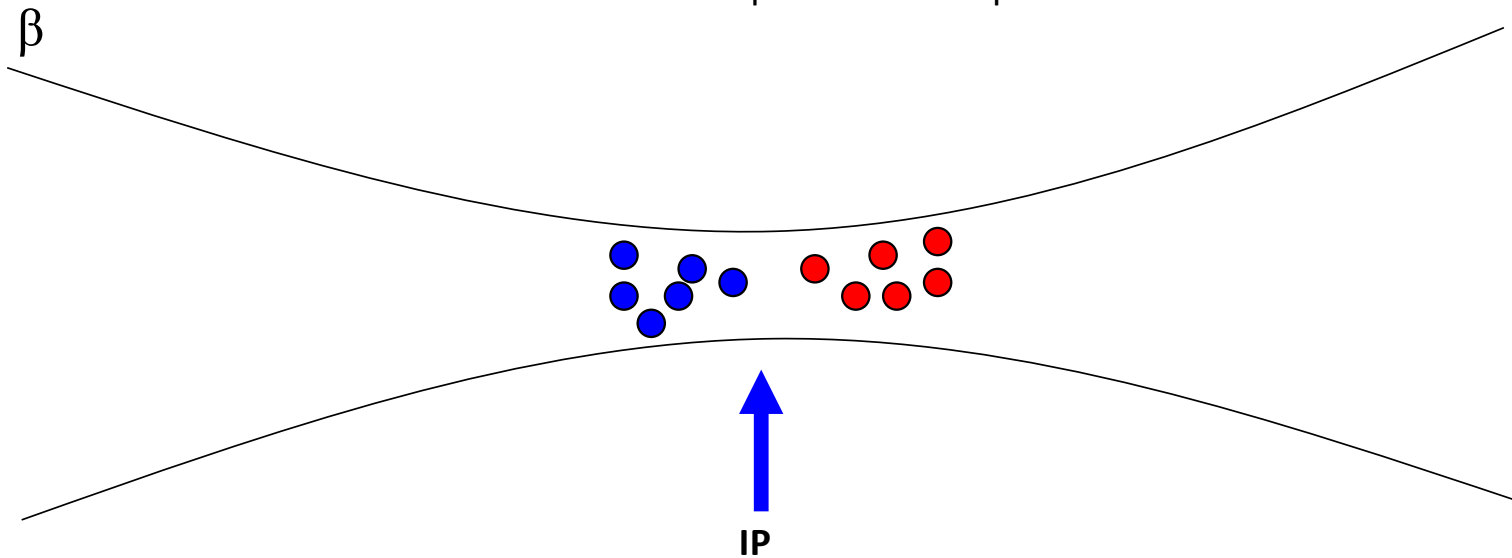

# Luminosità di un *collider*

Numero di particelle per fascio

$$L = \frac{N^{e^+} N^{e^-}}{4\pi\sigma_x \sigma_y} \times f_{\text{collisione}} \quad [\text{cm}^{-2} \text{sec}^{-1}]$$

Dimensioni trasverse dei fasci nell'IP:  
Si può arrivare a pochi millesimi di mm

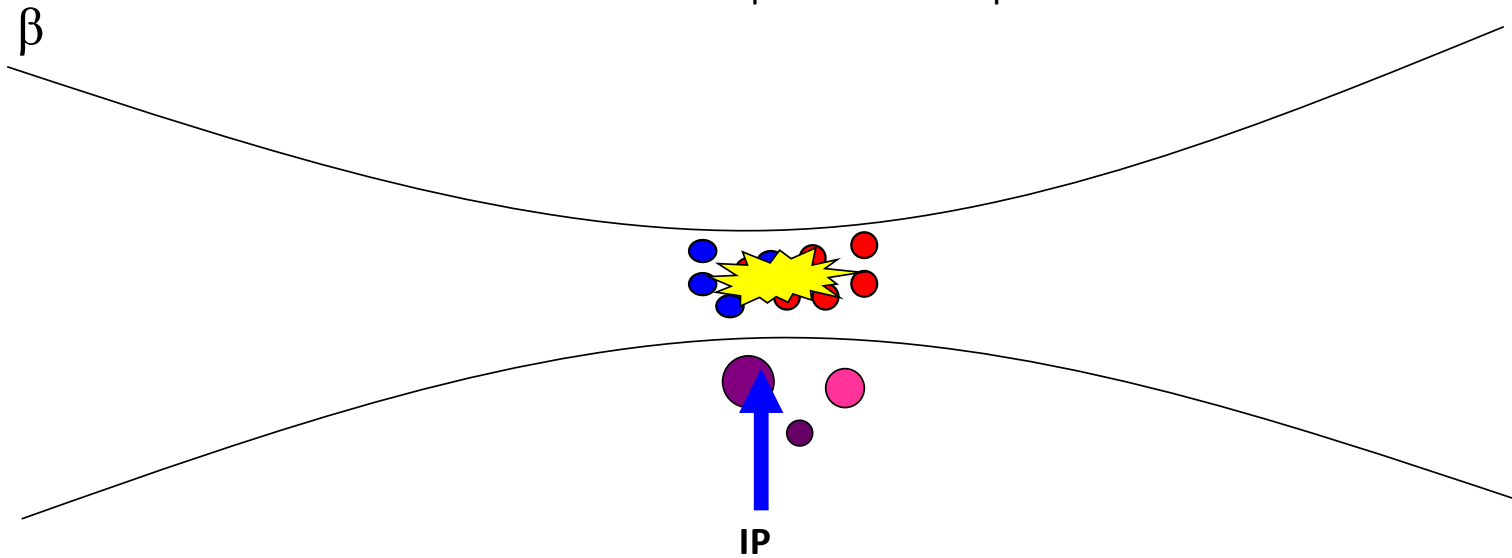

# Luminosità di un *collider*

Numero di particelle per fascio

$$L = \frac{N^{e^+} N^{e^-}}{4\pi\sigma_x \sigma_y} \times f_{\text{collisione}} \quad [\text{cm}^{-2} \text{sec}^{-1}]$$

Dimensioni trasverse dei fasci nell'IP:  
Si può arrivare a pochi millesimi di mm

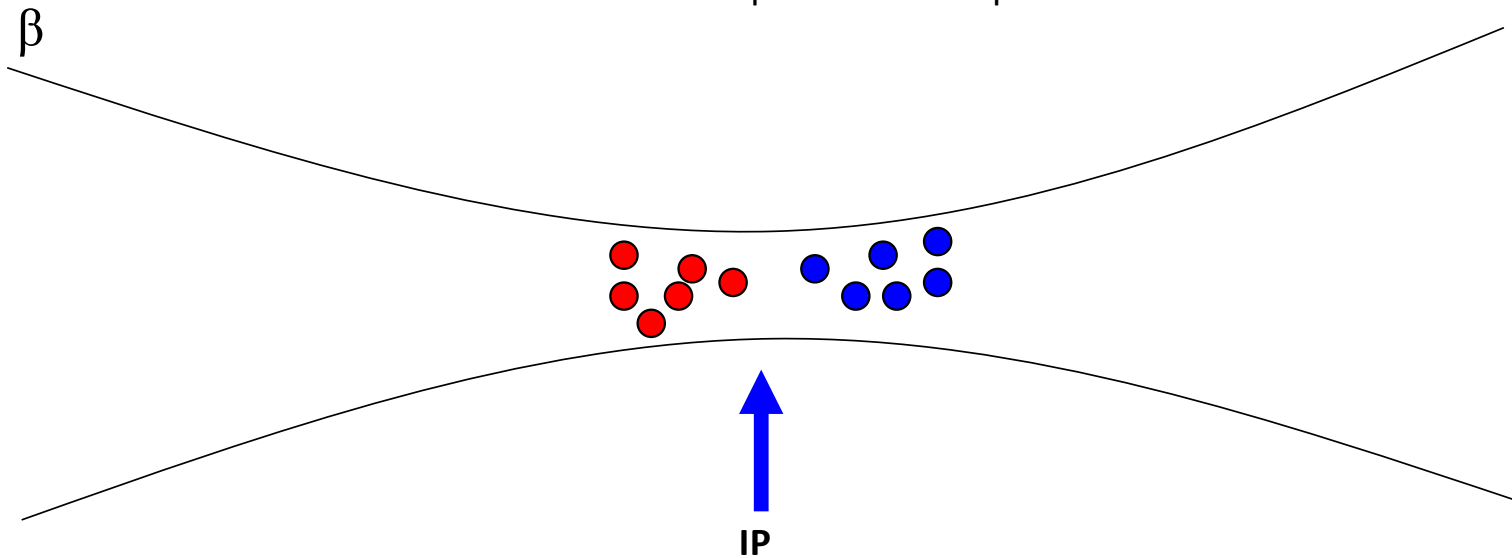

# Luminosità di un *collider*

Numero di particelle per fascio

$$L = \frac{N^{e^+} N^{e^-}}{4\pi\sigma_x \sigma_y} \times f_{\text{collisione}} \quad [\text{cm}^{-2} \text{sec}^{-1}]$$

Dimensioni trasverse dei fasci nell'IP:  
Si può arrivare a pochi millesimi di mm

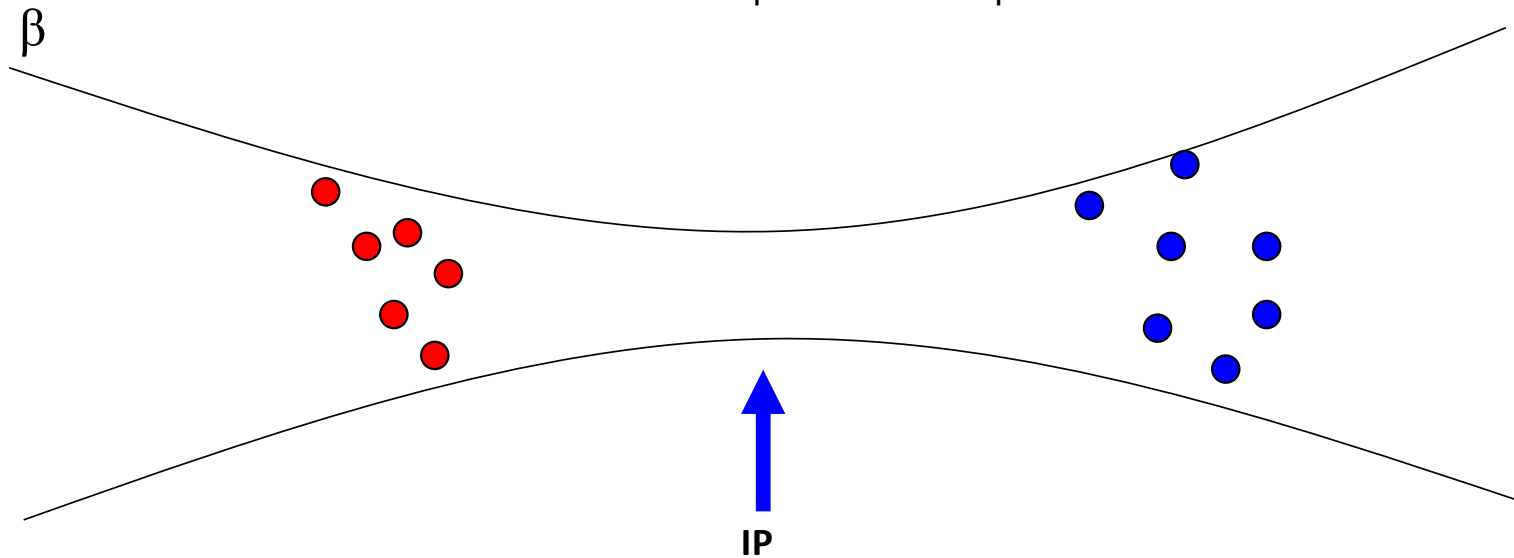

# Luminosità di un *collider*

Numero di particelle per fascio

$$L = \frac{N^{e^+} N^{e^-}}{4\pi\sigma_x \sigma_y} \times f_{\text{collisione}} \quad [\text{cm}^{-2} \text{sec}^{-1}]$$

Dimensioni trasverse dei fasci nell'IP:  
Si può arrivare a pochi millesimi di mm

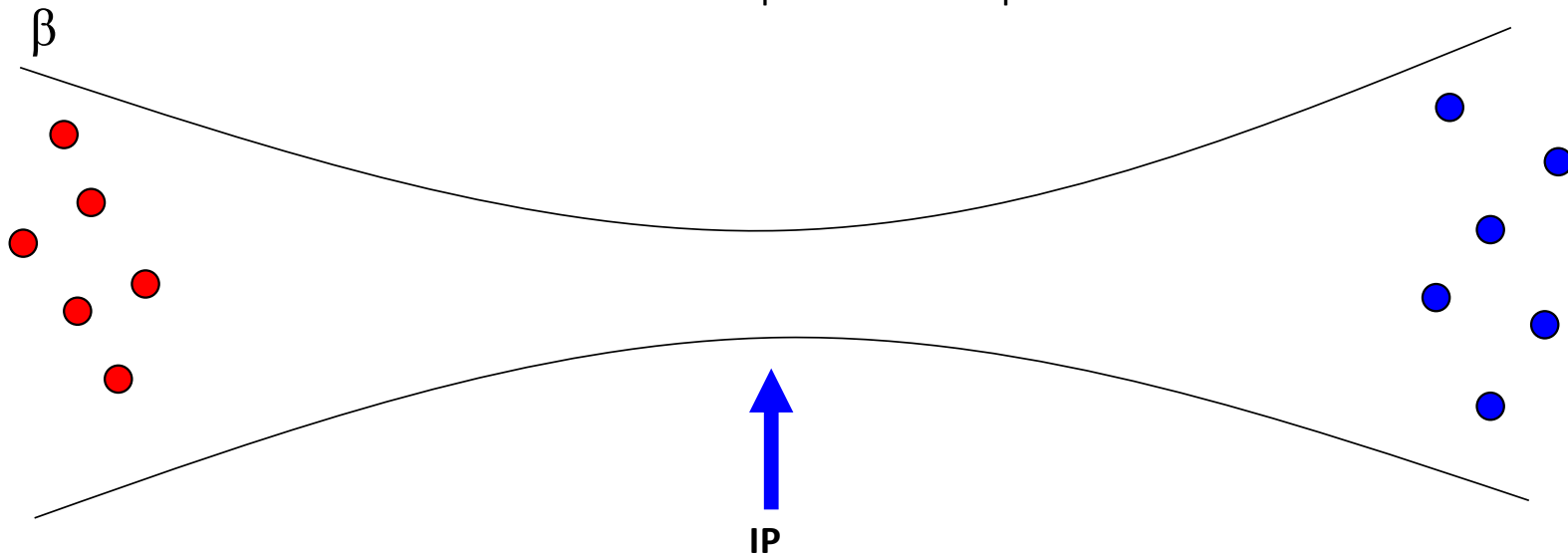

# Luminosità di un *collider*: esempio calcolo per DAΦNE

Produzione di  $\Phi$  a DAΦNE

$$L = \frac{N^{e^+} N^{e^-}}{4\pi\sigma_x\sigma_y} \times f_{\text{collisione}} \cong 10^{32} \text{ cm}^{-2} \text{ s}^{-1}$$

$\sim 2 \cdot 10^{10}$  (pointing to  $N^{e^+}$  and  $N^{e^-}$ )

$f_{\text{RF}} = 368.000.000 \text{ s}^{-1}$  (120 pacchetti) (pointing to  $f_{\text{collisione}}$ )

1 mm (pointing to  $\sigma_x$ )

10  $\mu\text{m}$  (pointing to  $\sigma_y$ )

$$\sigma_{\Phi} \sim 3 \cdot 10^{-30} \text{ cm}^2$$



frequenza degli eventi di produzione di  
particelle  $\Phi$   $L\sigma = 300$  eventi/s

# LHC (Large Hadron Collider) CERN

## LHC parametri

particelle collidenti protoni-protoni e anche ioni (Pb - Pb)

energia 7 TeV (massima per fascio)

numero di pacchetti 2808

angolo d'incrocio  $300 \cdot 10^{-6}$  rad

emittanza  $5 \cdot 10^{-10}$  m

$\sigma_x = \sigma_y$   $16 \cdot 10^{-6}$  m

circonferenza 27.8 Km

$B_{MAX \text{ dipoli}} = 83800$  Gauss con  $I = 11700$  A

$T = 1.9$  K

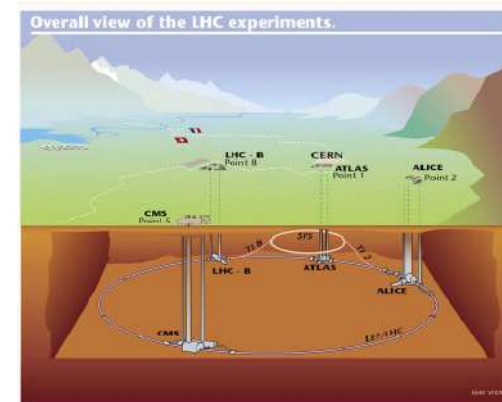
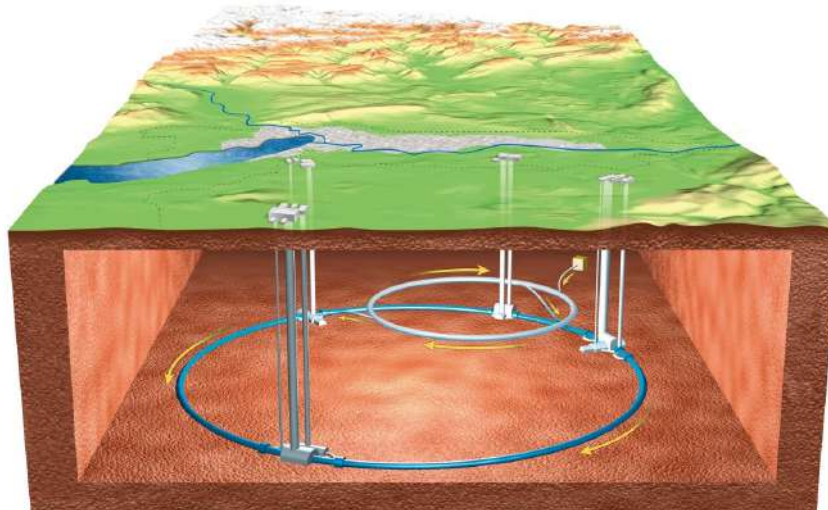
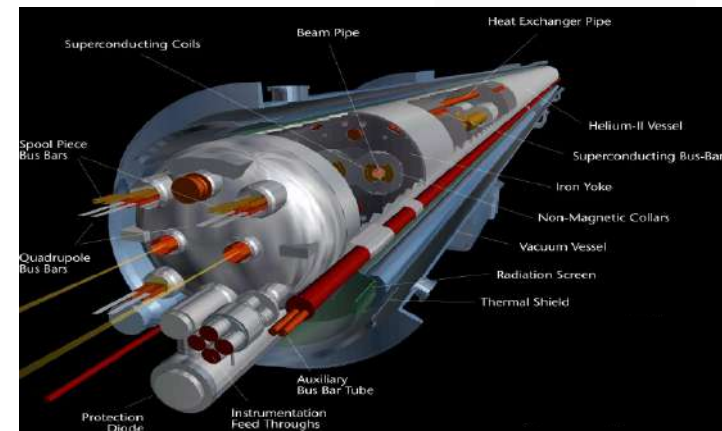
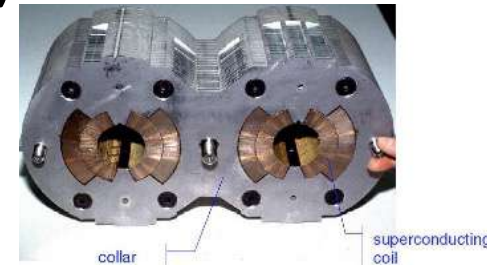



# LUMINOSITA' ED ENERGIA

Le collisione tra due fasci di particelle o tra un fascio di particelle e un bersaglio ...

Forniscono informazioni sui costituenti ultimi del nostro universo e sulle leggi che li governano (**microscopio**)

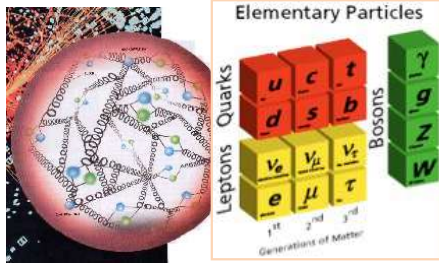

Ricreando **densità di energia** sempre più elevate, consente di risalire ai primi istanti di vita dell'Universo e di studiarne l'evoluzione (**macchina del tempo**)

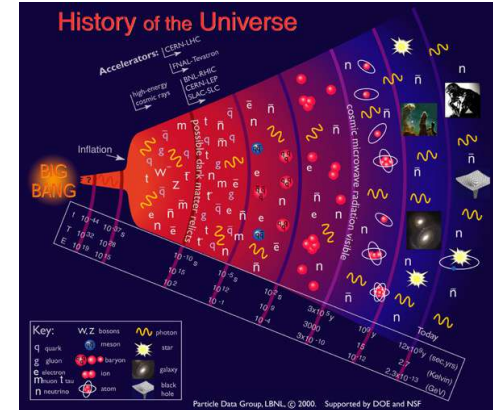

Quantità di eventi di fisica generati/statistica della misura

Numero di particelle per fascio

$$L = \frac{N_1 N_2}{4\pi\sigma_x \sigma_y} \times f_{\text{collisione}} \left[ \text{cm}^{-2} \text{s}^{-1} \right]$$

Dimensioni trasverse dei fasci nell'IP

In un collider la **frequenza con cui si producono gli eventi** cercati si può esprimere come il prodotto  $L \times \sigma$  ( $\sigma$ =sezione d'urto dell'evento cercato)

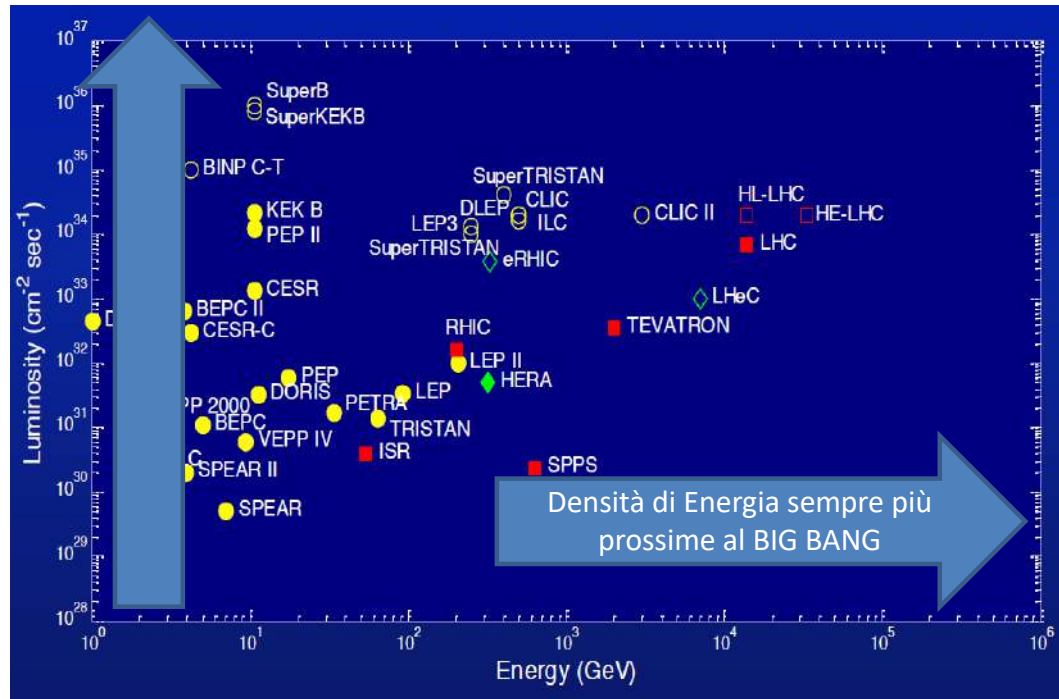

# LINEE DI RICERCA PRINCIPALI SUGLI ACCELERATORI DI PARTICELLE

Le **linee di ricerca** su cui maggiormente si investe nella fisica e tecnologia degli acceleratori di particelle riguardano:



Macchine **compatte** anziché acceleratori chilometrici come sorgenti di radiazione (es FEL, acceleratori medicali,...).

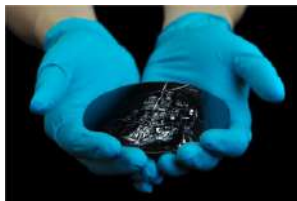

**Collider ad alta energia compatti per fisica fondamentale** (es. linear collider)

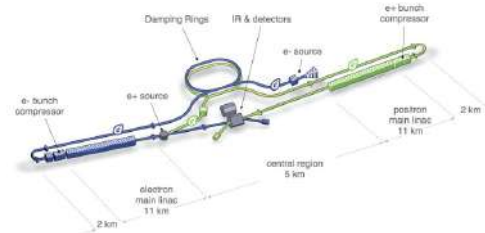

**Collider ad elevata luminosità** (superKEKB,...)

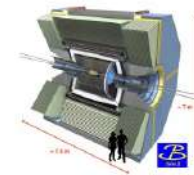

**Sorgenti di luce di sincrotrone di nuova generazione** (ESRF upgrade)



# LIMITS OF HIGH ENERGY CIRCULAR MACHINES

Hadron colliders (p,...)

$$\rho \cong \frac{p[GeV/c]}{0.3B}$$



The maximum magnetic fields reachable with superconducting Nb<sub>3</sub>Sn magnets is 16-17 T (8 T LHC)



Larger radius and/or new magnets (HTS, High Temperature Superconductors?)

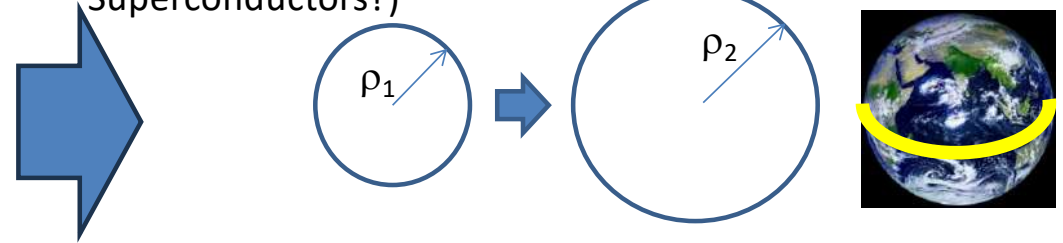

Larger radius or linear accelerator (limited luminosity and nm beam at IP)



Lepton colliders

$$U_{per\ turn} \propto \frac{\gamma^4}{\rho}$$

The limit even more than the maximum radius of curvature is given by the **power lost by synchrotron light emission**

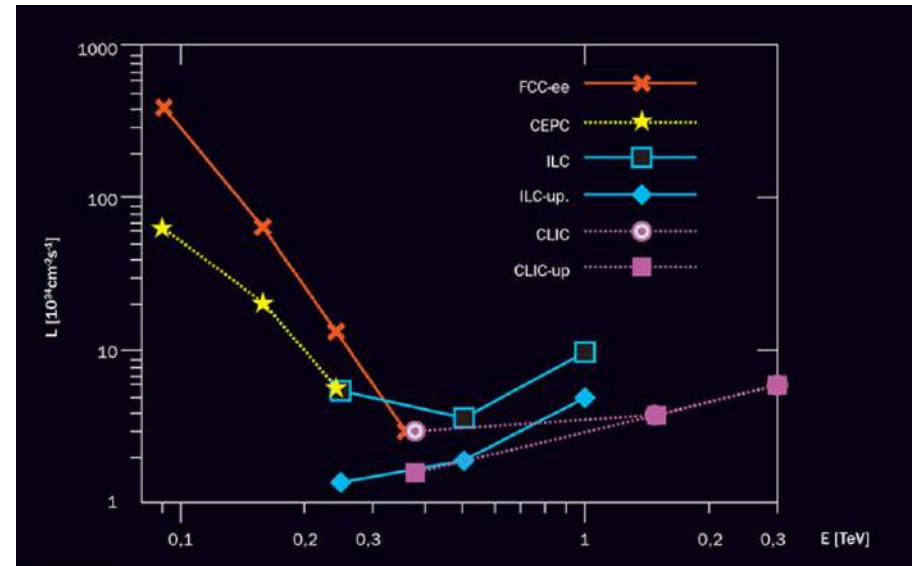
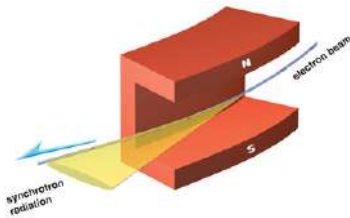

# HIGH ACCELERATING FIELD $\Rightarrow$ NORMAL CONDUCTION HIGH FREQUENCY

The basic idea is to **concentrate electromagnetic energy** in smaller volumes to increase its density and, therefore, the value of the accelerating field.

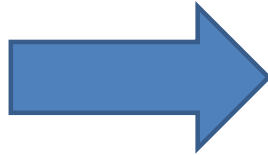

## High frequency metallic structures

Metallic structures working at **12 GHz** can reach up to **100-150 MV/m** accelerating field gradient with a small number of discharges: **vacuum breakdown** is a complex phenomena still under investigation.

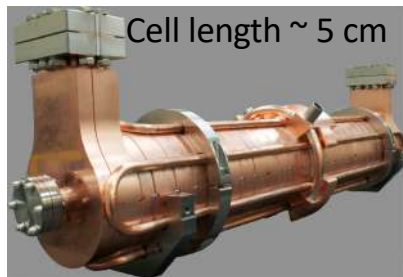

Cell length  $\sim$  5 cm

Cell length  $\sim$  2.5 cm



Cell length  $\sim$  1 cm



Cell length few mm



S-band  
(3 GHz)

C-band  
(6 GHz)

X-band  
(12 GHz)

Ka Band  
(36 GHz)

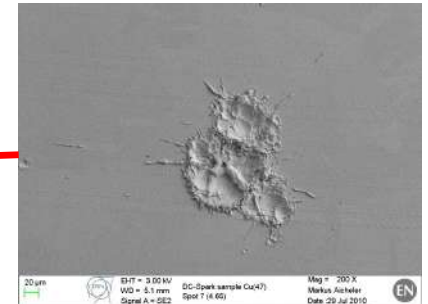
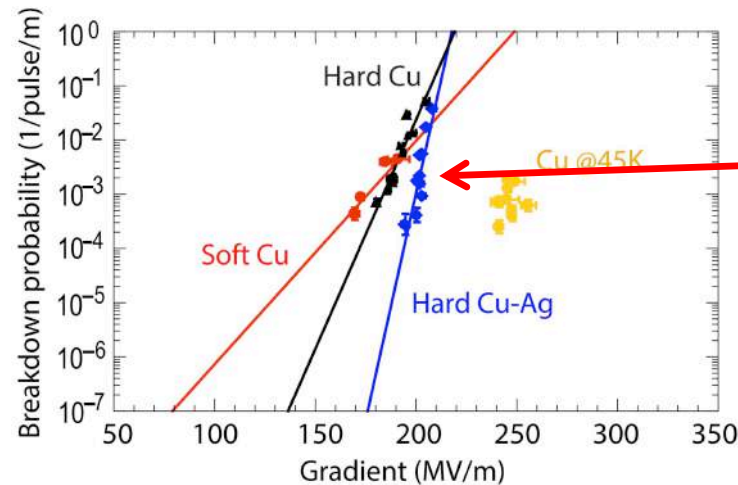

### R&D on NC LINACS @INFN

- **EuPRAXIA@SPARC\_LAB (LNF)**
- **ASTERIX** experiment. Funded by INFN CSN5.
- **MICRON** experiment. Funded by INFN CSN5.

# HIGH ACCELERATING FIELD $\Rightarrow$ DIELECTRIC STRUCTURES POWERED BY LASERS

**Lasers** are intense pulsed sources of electromagnetic field and at the working frequencies of lasers ( $10^{13}$ - $10^{15}$ Hz) metallic structures cannot be used (dissipation,...)

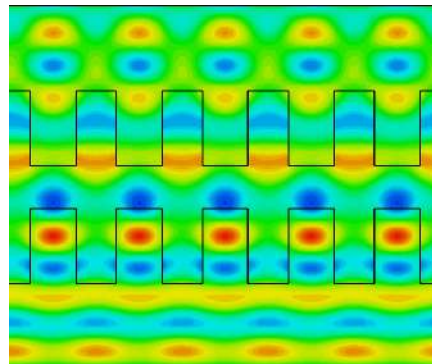
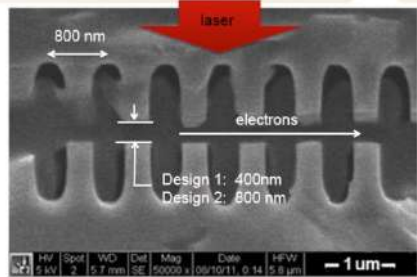

Dielectric structures can be used

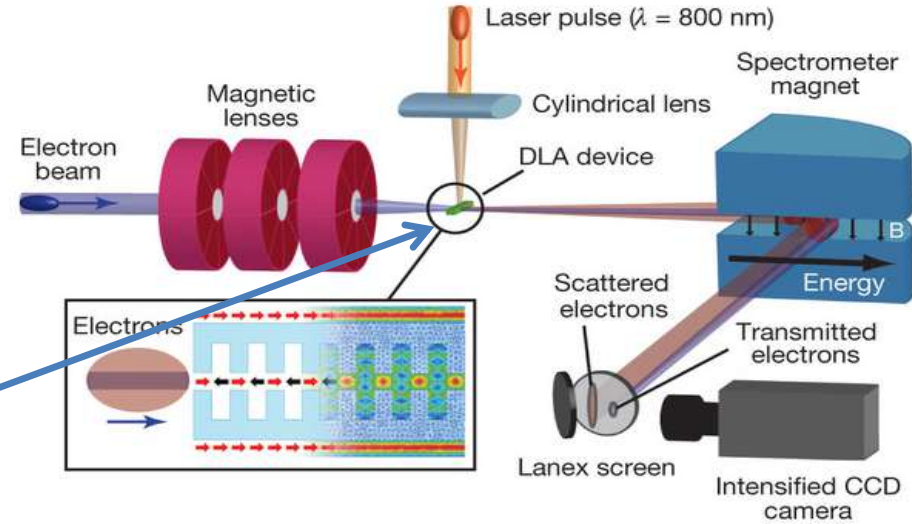

Gradient up to **5 GV/m** have been measured

Main problems:

- **Low charge** (university-scale/small lab/medical applications up to now)
- **Low energy**: short devices (<1 mm), to achieve high energies thousands of devices have to be synchronized
- Alignment and stabilization problems
- Wakefield instabilities

**MICRON** experiment. Funded by INFN CSN5.

# PLASMA ACCELERATORS

RF Cavity



1 meter

Electric field  $\sim 100$  MV/m

Plasma Cavity

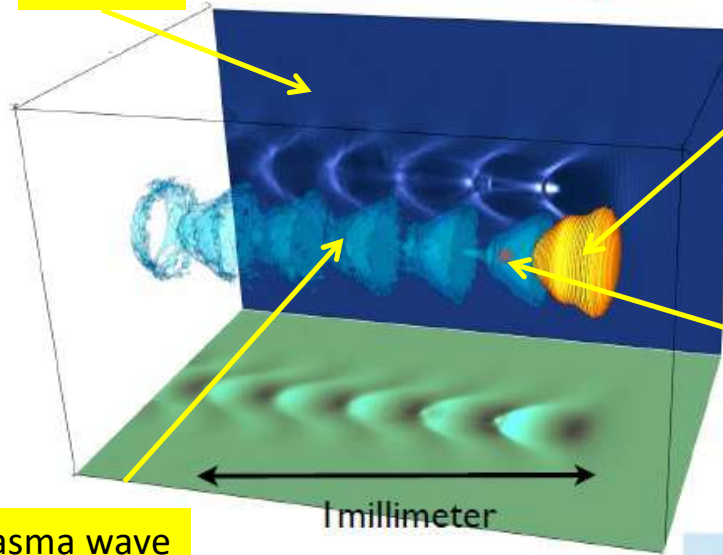

Laser or beam pulse (driver)

Accelerated beam (witness)

Plasma wave

Field up to 100 GV/m

km  $\longrightarrow$  m

Accelerating bubble

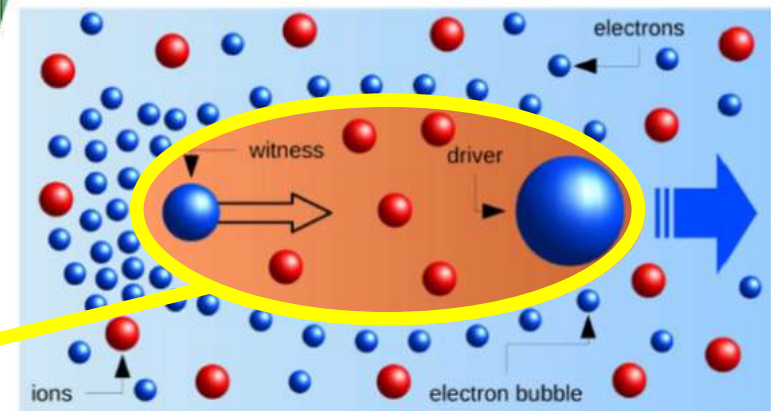

# PLASMA ACCELERATION MECHANISM

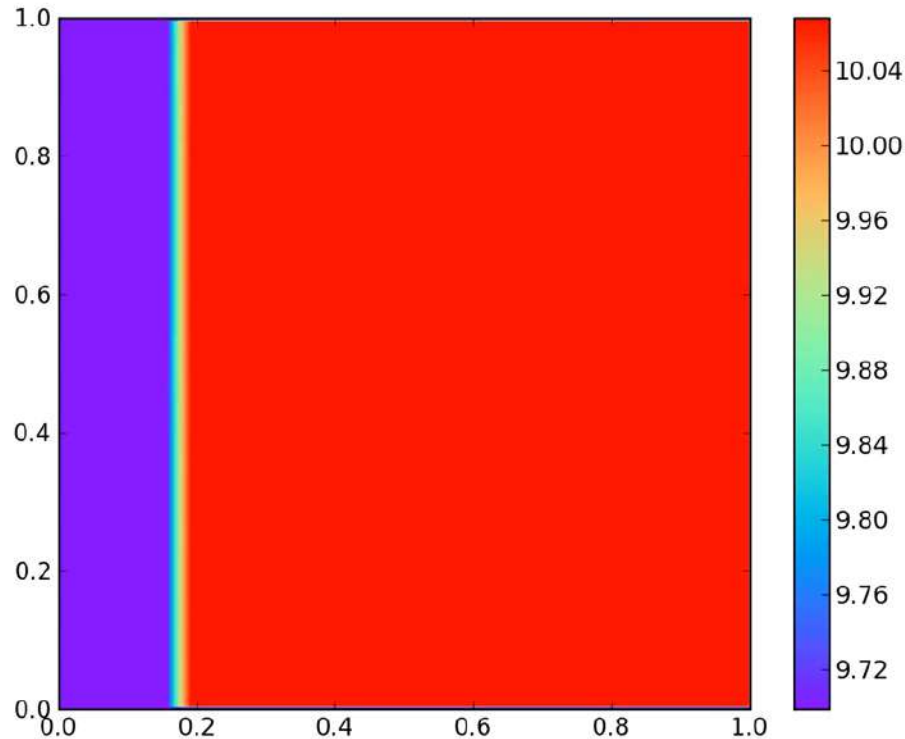

$E_{\text{acc}} \approx 40 \text{ GV/m}$  in a 20 cm channel with a 850 TW laser

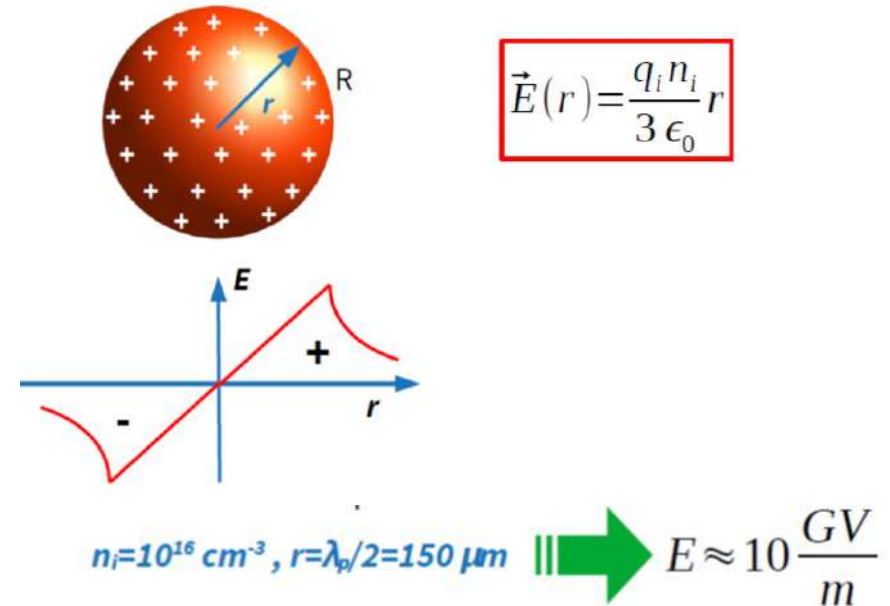

The laser or beam pulse creates a moving bubble (with velocity  $\sim c$ ) in the plasma, which allows continuous acceleration of the electron beam

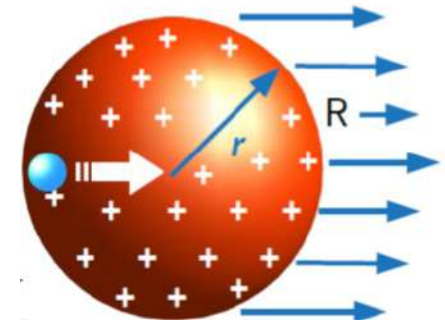

# ACCELERAZIONE LASER-PLASMA (LWFA)

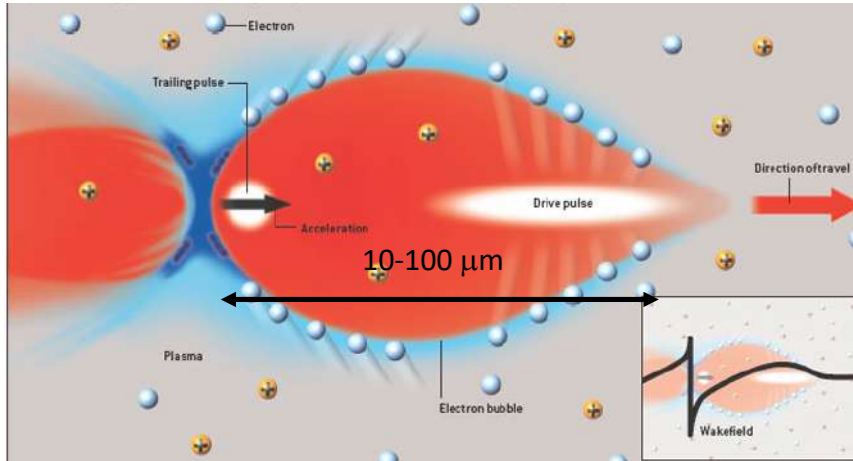

laser Gas jet

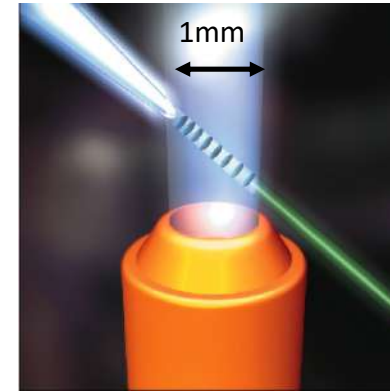

VIDEO

Elettroni accelerati

$$E_0 = \frac{m_e c \omega_p}{e} \approx 100 \left[ \frac{\text{GeV}}{m} \right] \cdot \sqrt{n_0 [10^{18} \text{ cm}^{-3}]}$$

4.25 GeV beams have been obtained from 9 cm plasma channel powered by 310 TW laser pulses (15 J)



Leader mondiale: BELLA Center, Accelerator Technology and Applied Physics Division  
Lawrence Berkeley National Laboratory

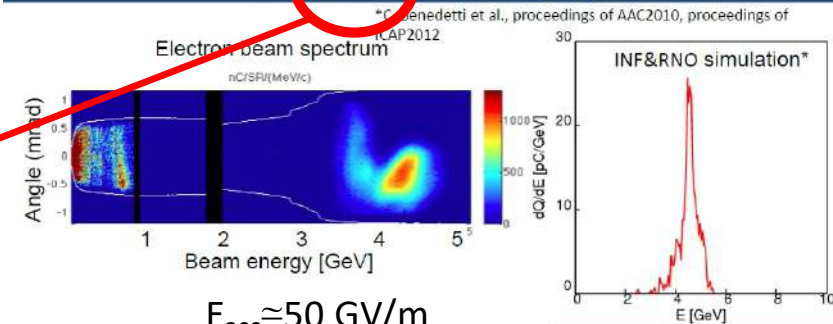

$E_{\text{acc}} \approx 50 \text{ GV/m}$

- **Laser** (E=15 J):
  - Measured longitudinal profile ( $T_0 = 40 \text{ fs}$ )
  - Measured far field mode ( $w_0 = 53 \mu\text{m}$ )
- **Plasma**: parabolic plasma channel (length 9 cm,  $n_0 \sim 6-7 \times 10^{17} \text{ cm}^{-3}$ )

W.P. Leemans et al., PRL 2014

	Exp.	Sim.
Energy	4.25 GeV	4.5 GeV
$\Delta E/E$	5%	3.2%
Charge	$\sim 20 \text{ pC}$	23 pC
Divergence	0.3 mrad	0.6 mrad

# ACCELERAZIONE LASER-PLASMA: MULTI-GeV LINAC

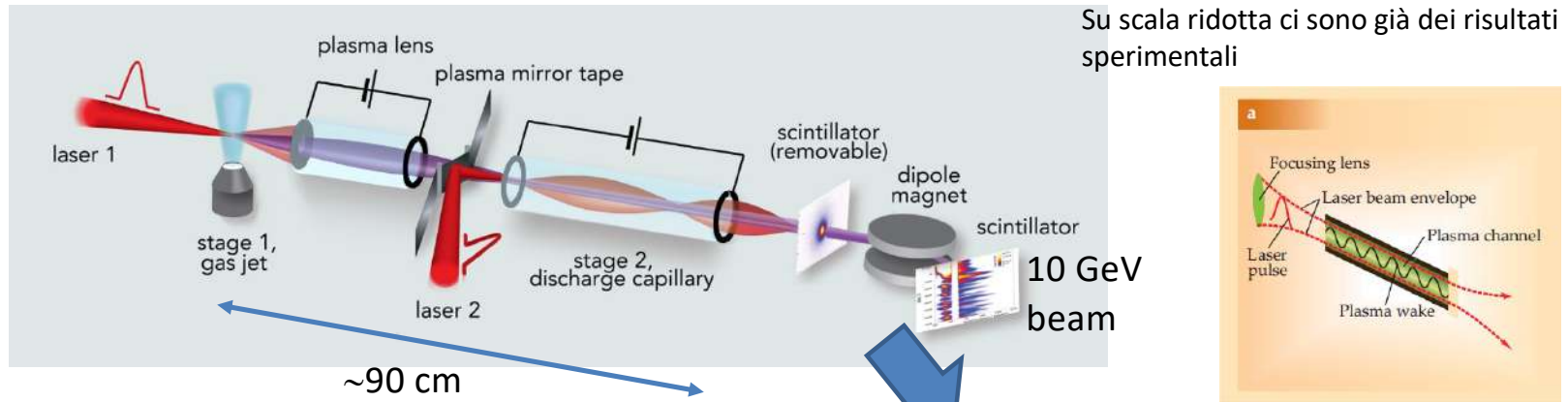

**SORGENTI DI RADIAZIONE COMPATTE BASATE SU LPWA**

**LPWA LINEAR COLLIDER?**

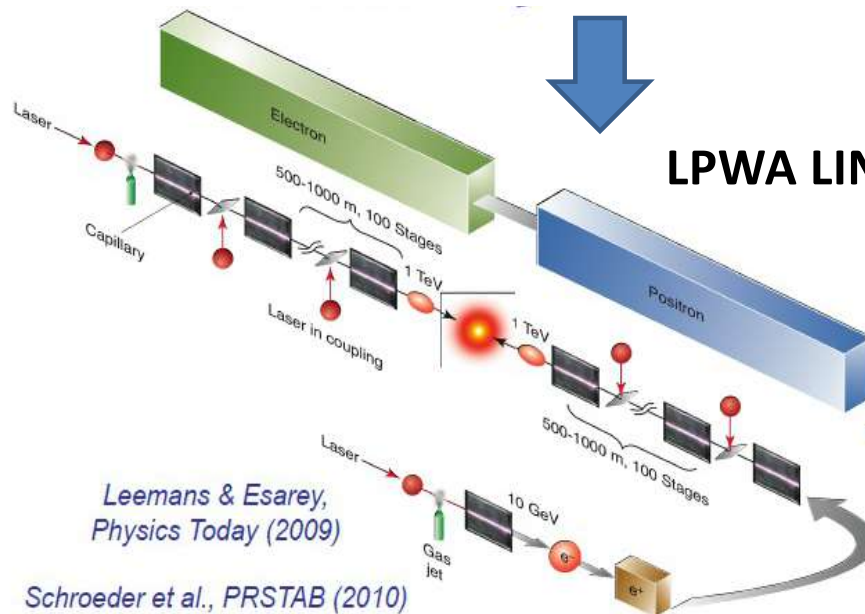

- LPA-linear collider:
- 50 stages (1 TeV collider)
- 10 GeV/stage
- requires ~10 J laser (at tens of kHz, hundreds of kW)
- $n=10^{17} \text{ cm}^{-3}$  (set by laser depletion) <sup>2</sup>

# ULTRA-HIGH INTENSITY LASER FACILITIES

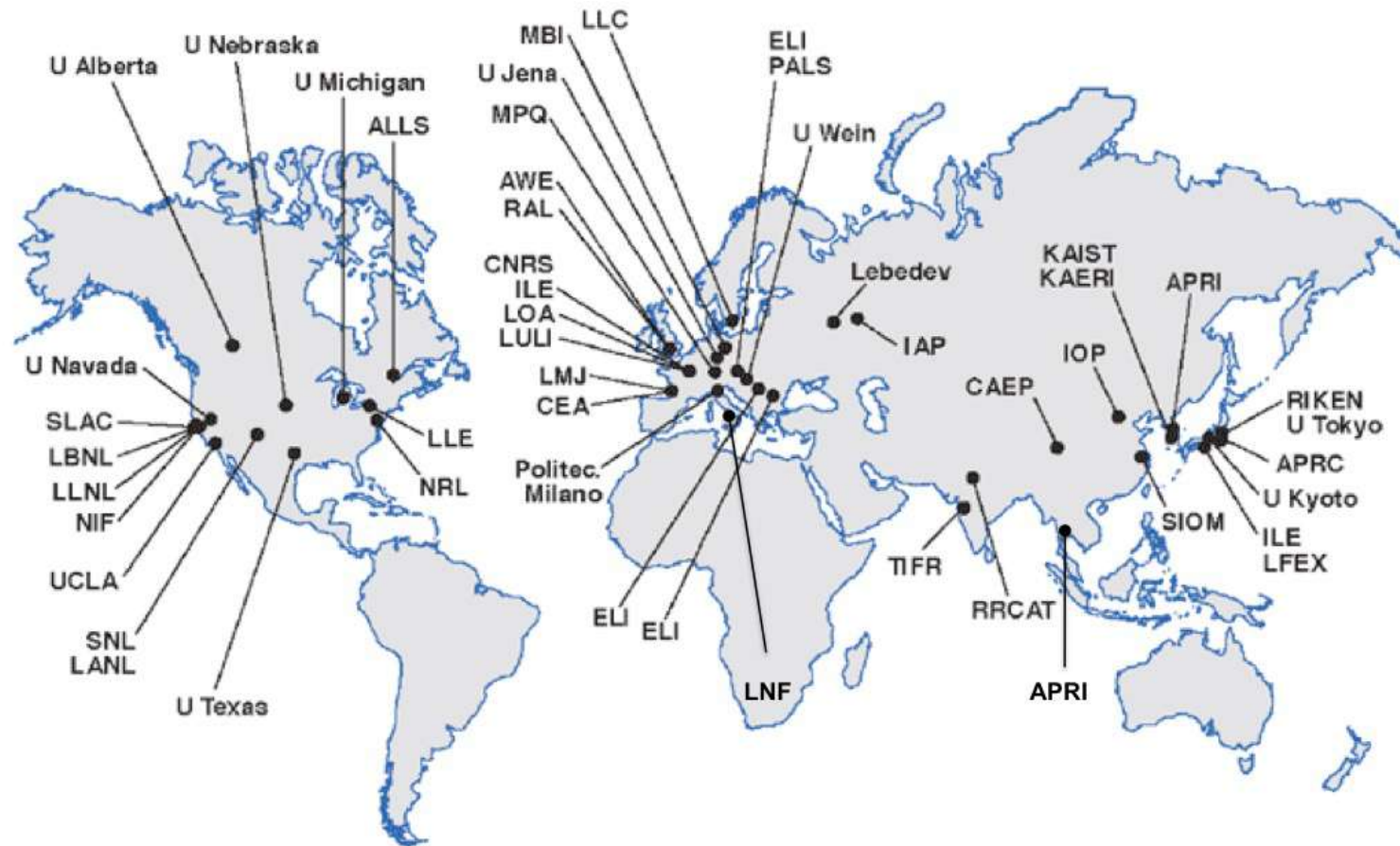

<http://www.icuil.org/>

# ULTRA-HIGH INTENSITY LASER FACILITIES

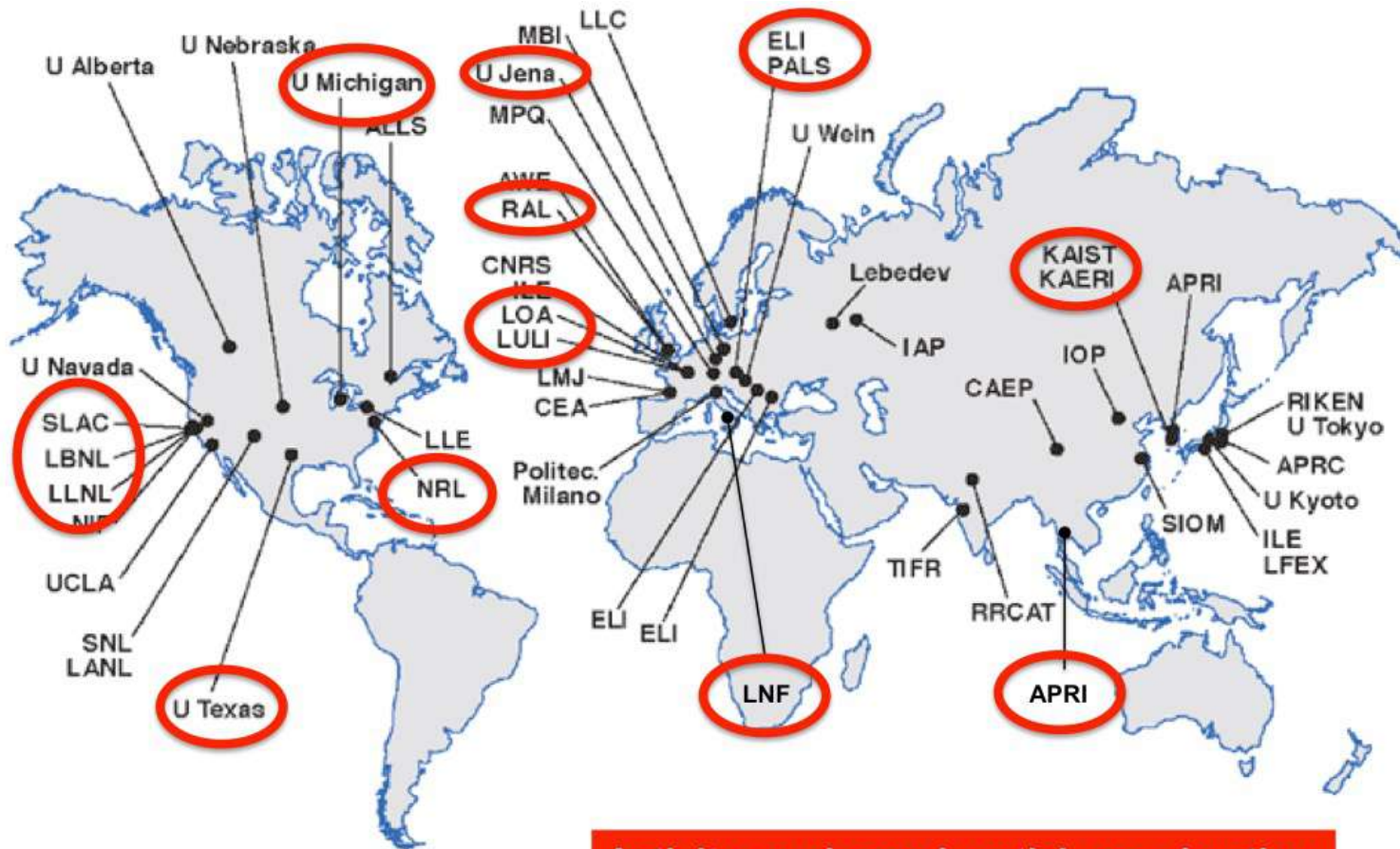

<http://www.icuil.org/>

Activity on charged particle acceleration

# EUPRAXIA@SPARC\_LAB (LNF) PROJECT

Plasma acceleration R&D is focused in several directions:

- **beam quality improvement, stability**
- **repetition rate**
- **staging for maximum energy improvement**
- ...



**European project (ESFRI roadmap)** with two pillars (Frascati and ELI-Praga) for implementation of infrastructures based on plasma wakefield acceleration producing high quality beams for different applications (2028-2030)

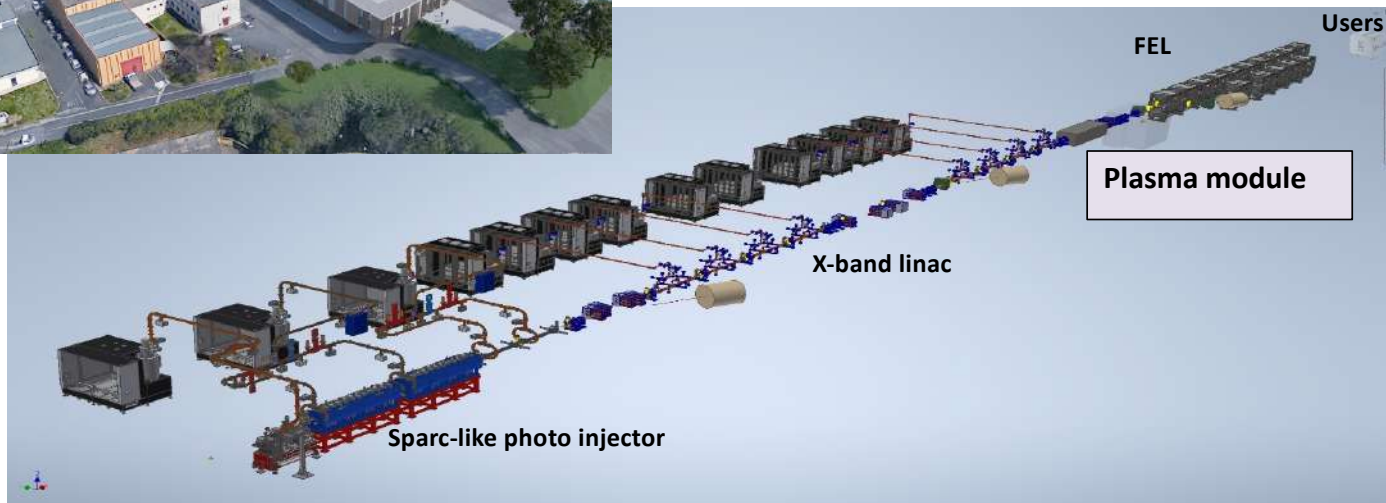

# EuPRAXIA@SPARC\_LAB

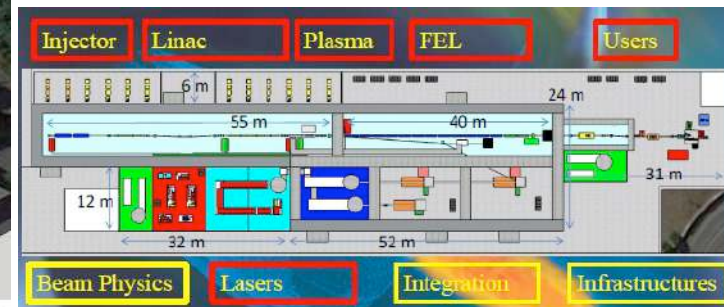
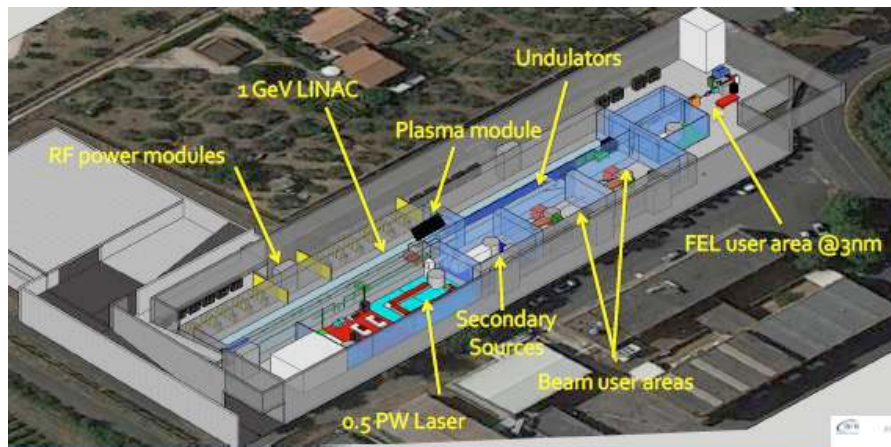

# CERN FUTURE COLLIDERS OPTIONS

## FCC: MAIN OPTION

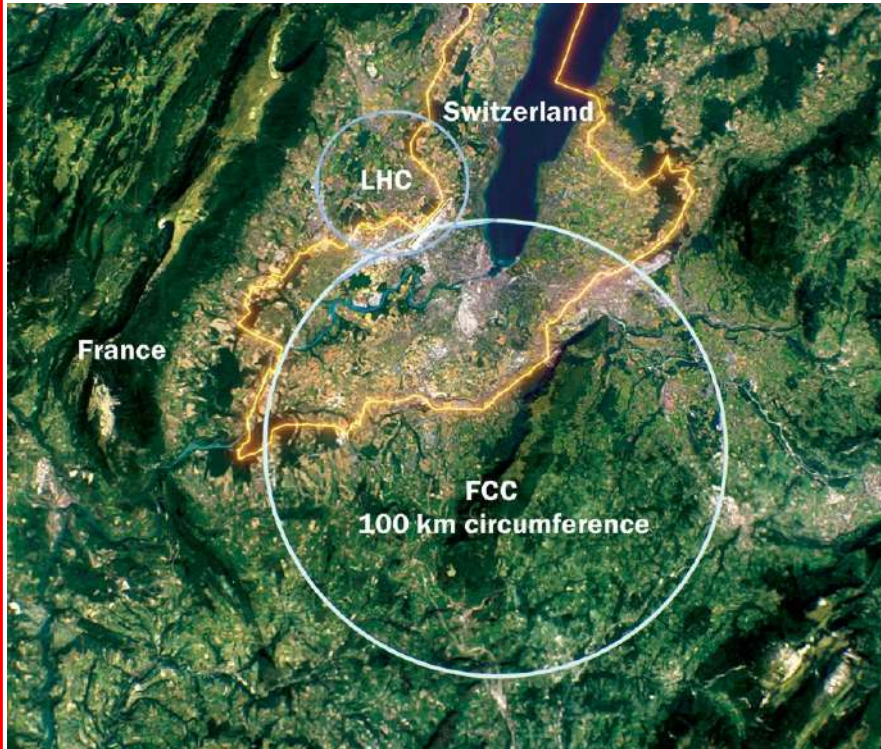

**CIRCULAR COLLIDER ~90 km**

FCC-ee (phase I), ~90 GeV/baam

FCC-hh (phase II), 85 TeV, 14 T dipole magnets

## CLIC- LINEAR COLLIDER

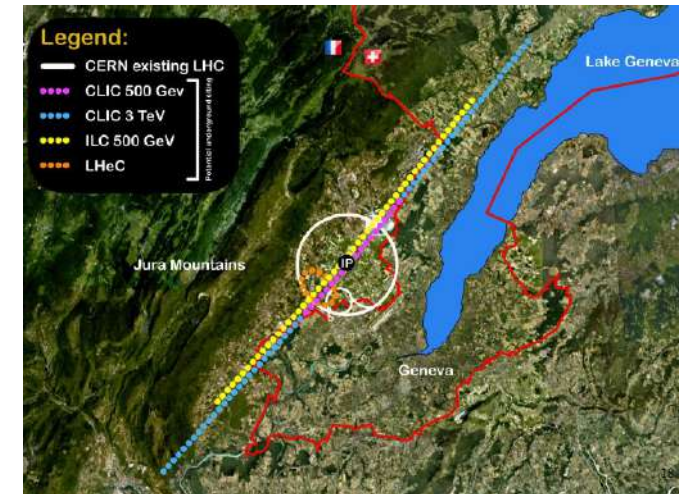

12 GHz (X-band): 100 MV/m



**LINEAR COLLIDER e<sup>+</sup>/e<sup>-</sup>**

~50 km, 1.5 TeV, 100 MV/m accelerating cavities



I'm coordinating INFN-ACCELERATORI that is a **committee**, composed of various specialists with extensive experience in accelerators and accelerator-related technologies, which **aims to**:

<https://acceleratori.infn.it/?lang=en>

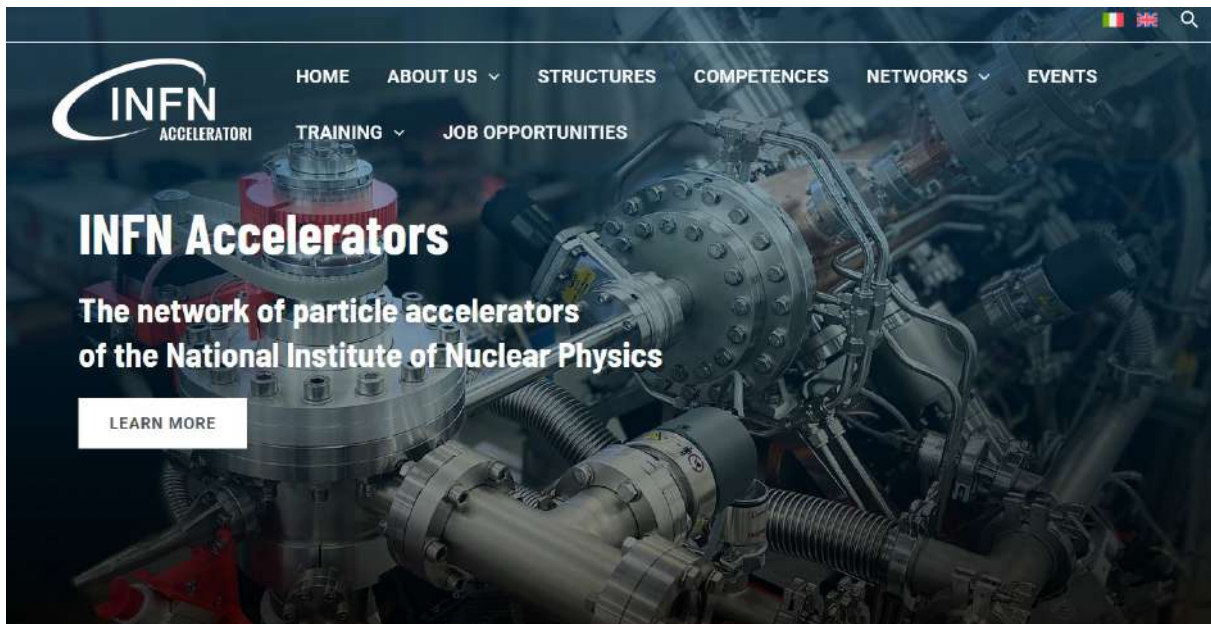

- Serve as a **link** between the community of accelerator experts within the INFN and the Institute's top governing bodies (President, Executive Board, and Board of Directors).

- **Promote networks** the establishment of thematically aligned among accelerator specialists on topics of significant interest

- Foster the **harmonization of expertise** and technical infrastructure within the Institute in the field of accelerator science and technology.

- **Encourage** and support participation in regional, national, and international funding calls.

- **Provide advisory input**, upon request by INFN management, on matters related to particle accelerators, including the promotion and participation in projects, as well as strategic guidance in this domain.

# CONCLUSIONI

Gli **acceleratori di particelle** sono **strumenti** utilizzati per una **straordinaria varietà di applicazioni** che vanno dalla fisica delle alte energie e della materia alla diagnostica e terapia in ambito medico, dall'industria ai sistemi di sicurezza.

⇒GLI ACCELERATORI DI PARTICELLE RIMANGONO **UNO DEGLI STRUMENTI PIU' POTENTI NELL'AMBITO DELLA RICERCA** IN FISICA DELLA MATERIA E DELLE PARTICELLE CON **FONDAMENTALI APPLICAZIONI IN AMBITO MEDICO E INDUSTRIALE.**

⇒LA PROSPETTIVA DEL LORO UTILIZZO IN AMBITO ENERGETICO (ADS) VA ASSOLUTAMENTE **ESPLORATA E VALUTATA** CON UN IMPEGNO A LIVELLO INTERNAZIONALE

⇒UNA **SALTO NELLA TECNOLOGIA E' ORMAI NECESSARIO**

⇒**NUOVE IDEE** E IMPORTANTI RISULTATI HANNO APERTO NUOVE E PROMETTENTI STRADE

⇒L' R&D NELLA FISICA E TECNOLOGIA DEGLI ACCELERATORI DI PARTICELLE RIMANE UNO DEI SETTORI **PIU' ENTUSIASMANTI DELLA RICERCA** IN FISICA APPLICATA IN CUI **FANTASIA E CREATIVITA'** SONO GLI INGREDIENTI FONDAMENTALI

In quali direzioni si sta andando per rendere le macchine acceleratrici sempre più **compatte ed efficienti**?

Quali sono i **limiti e le sfide** nell'ambito della fisica e tecnologia degli acceleratori di particelle?

Quali i **possibili scenari** futuri?

**UN SENTITO GRAZIE PER LA VOSTRA ATTENZIONE!!!!**

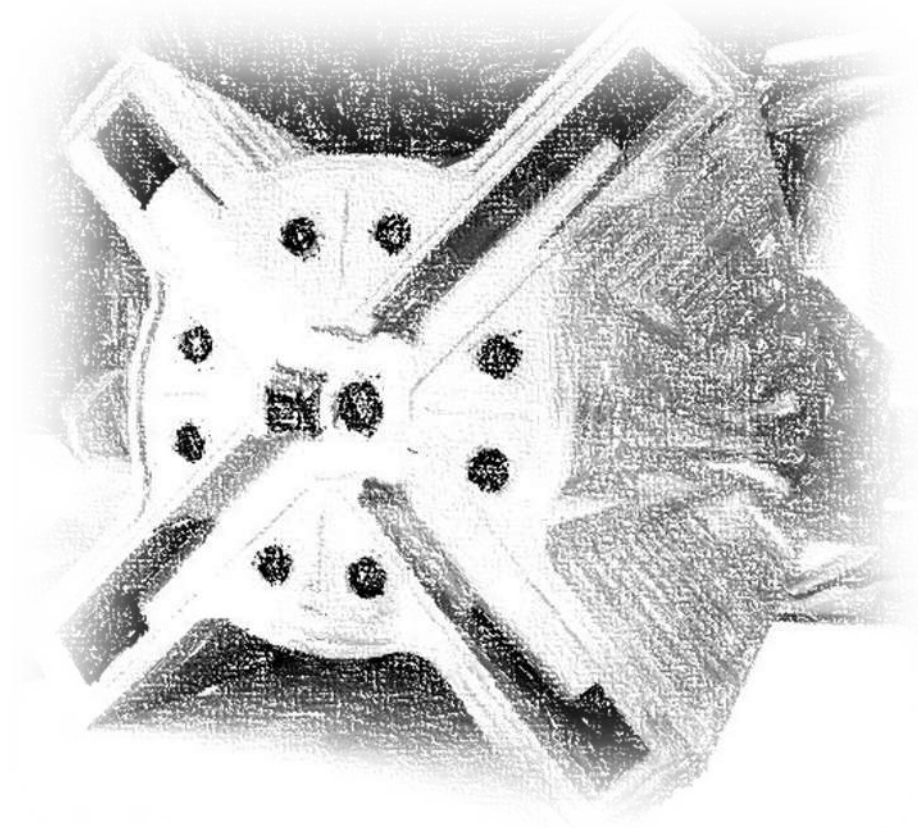

**Ringrazio...**

M. E. Biagini, A. Biagioni, M. Boscolo, F. Cardelli, A. Cianchi, L. Faillace, M. Ferrario, A. Gallo, S. Guiducci, C. Milardi, A. Mostacci, R. Pompili, R. Pompili, B. Sciascia e tutti gli autori da cui ho preso immagini e trasparenze.

# Alcuni link Bibliografici

## [Scuole acceleratori](#)

CERN Accelerator School:

<http://cas.web.cern.ch/cas/>

<http://cdsweb.cern.ch/record/235242?ln=it>

## [JUAS](#)

<https://espace.cern.ch/juas/SitePages/Home.aspx>

USPAS

<http://uspas.fnal.gov/>

M. Sands, The Physics of Electron Storage Rings: An Introduction, SLAC- 121 UC-28 (ACC)

<http://www.slac.stanford.edu/pubs/slacreports/slac-r-121.html>

Helmut Wiedemann, Particle Accelerator Physics, Springer-Verlag Berlin Heidelberg , 2007

Animazione LINAC SLAC

<http://lcls.slac.stanford.edu/AnimationViewLCLS.aspx>